

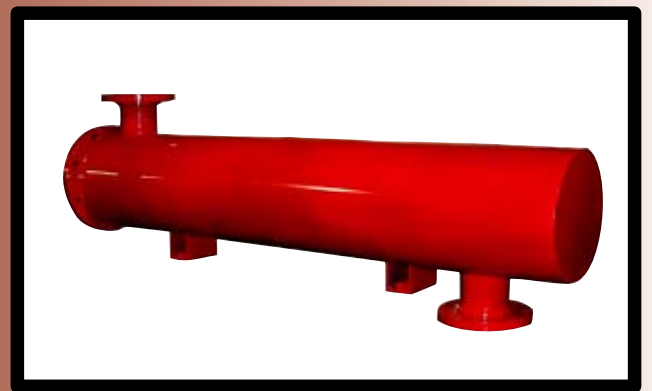

Circulation Heaters



Introduction

Heatrex designs and manufactures commercial and industrial electric heating and control systems that set the industry standard for excellence. The company's heating solutions reflect more than 80 years of innovation, product quality and efficient service.

Our product offering ranges from tubular heating elements to the most sophisticated, custom designed systems as described in this catalog. Heatrex's attention to detail and rigorous testing give worldwide customers premium products that they receive quickly and at a fair market price.

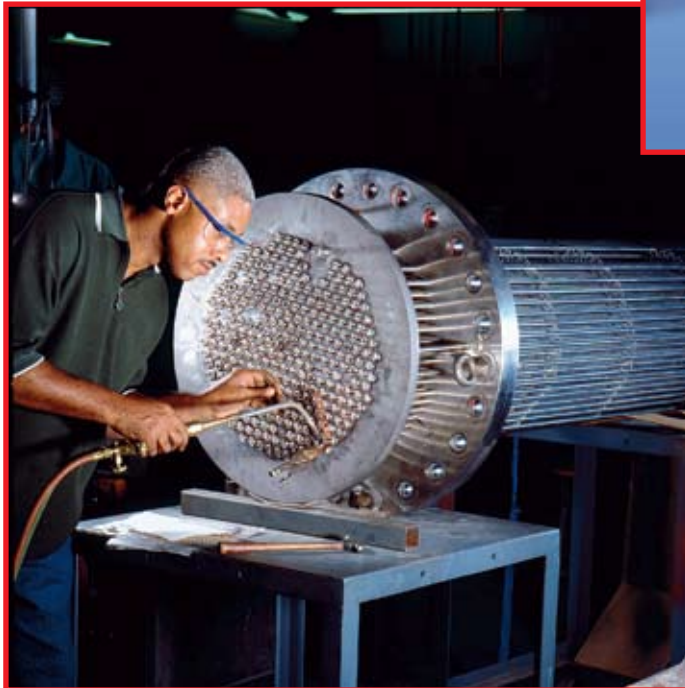

Table Of Contents

Circulation Heaters	2-23
Standard Construction	2
Typical Applications	3
System Configurations	3-4
Engineering Information	5-7
Dimensional Drawings	8
Mounting Options	9
Mechanical and Electrical Guidelines	10-11
Special Features	12-15
Multi-Purpose Heater Listings	16-17
Stainless Steel Heater Listings	18-19
Oil Heater Listings	20-21
Water Heater Listings	22
Mini-Booster Compact Water Heaters	23
How to Order	23
Control Panels	24-26
Contactor Control Panels	24
SCR Control Panels	25
Special Features	26
Tank Heaters	27
Open Coil Heating Elements	27
Storage Tank Heaters	27
Railroad Tank Car Heaters	27
Limited Warranty	28

Circulation Heaters

Standard Construction

Heatrex is known in the electric heating industry as a provider of custom designed, quality equipment. The standard circulation heater offering is described here.

The standard circulation heater construction includes an Heatrex Pipe or Pipe Flange Immersion Heater mounted in a thermally insulated pressure vessel with inlet and outlet nozzles.

A factory installed and pre-wired thermostat provides automatic process temperature control. Six heater mounting options are available to meet your specific installation requirements.

Immersion Heater

Designed and built by Heatrex, all pipe and pipe flange immersion heaters include these standard features.



Industrial Grade tubular elements are manufactured by Heatrex. The .475" diameter design provides extra electrical insulation for better dielectric strength.

Element Spacers, made from material similar to the element sheath, maintain a uniform distance between elements. This prevents hot spots that can reduce heater life and burn temperature sensitive materials flowing through the circulation heater. Spacers are perforated to allow for maximum flow and are installed in a manner to allow the heating element to expand and contract freely.

Element Bends are repressed 360° at the U-bend area to improve dielectric insulation integrity and to prevent potential hot spots.



Moisture-Resistant Epoxy Terminal Seals are standard for all circulation heater designs with maximum process temperatures of 250° F.

Permanent Bus Bars are provided to prevent field failures due to loose electrical connection. Pressure connectors are attached to the bus bars for field wiring of heavy gauge wire. Copper bus bars are standard. Stainless steel bus bars are required for high temperature applications.



Thermostat

An Heatrex Type DA thermostat is factory-mounted and prewired to give automatic process temperature control. The standard range is 60-250° F. Its liquid-filled sensing bulb has an inherent sensitivity of $\pm 5^\circ$ F; however, the actual process temperature differential depends on a number of application factors.

The Type DA thermostat comes complete with integral On/Off switch, pilot light and external adjusting knob. Both two and three-pole models are available. Heaters provided with pilot duty thermostats require field wiring to a magnetic contactor. See Table IV on page 10.



Circulation Heaters

Typical Applications

Heatrex circulation heaters are used to maintain, raise, preheat and boost process temperatures from -50° F to 1200° F for a wide variety of liquids and gases found in commercial, industrial and military applications.

- Adhesives
- Air Heating (Process)
- Ammonia
- Anodizing Equipment
- Automotive and Engines
- Chemical Processing
- Curing
- Cryogenic Processing
- Degreasing Tanks
- Desalination Equipment
- Dessicant Drying
- Drying
- Food Processing
- Freeze Protection
- Fuel Oils
- Gasoline Refining
- Heat Transfer Systems
- High Pressure Air or Gases
- Hydraulic Oils
- Laboratory Work
- Lubrication Oils
- Metal Cleaning Baths
- Nitrogen
- Oil Purifiers
- Oil Refining
- Oils
- Paint Lines
- Pasteurizing
- Pipeline Heating
- Plastic Machinery and Processes
- Platens
- Plating Tanks
- Preheating
- Presses
- Process Air and Liquids
- Purification Systems
- Rinsing/Cleaning
- Rolls and Cylinders
- Steam Heating
- Superheating
- Tank Heating (Process, Storage)
- Textiles
- Wash Tanks
- Waste Water/Sewage Treatment
- Water (Deionized, Potable, Process)

System Configurations

Closed Loop Systems

The circulation heater is installed in a system where the liquid or gas to be heated is recirculated through the heater in a closed loop configuration.

Applications of this method fall into the two distinct categories of Indirect and Direct Heating.

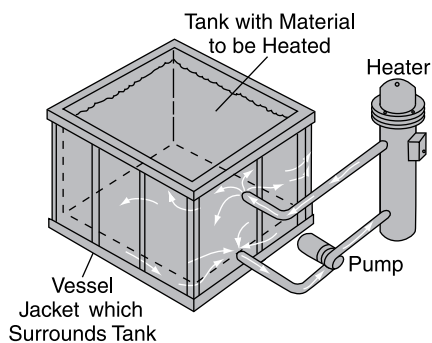

Indirect Heating:

A heating medium such as Dowtherm, Therminol, ethylene glycol, water, oil or steam is heated as it flows through the heater. The heating medium is continuously recirculated through coiled tubing, pipes or vessel jackets which are wrapped around or inserted directly into storage tanks, vessels, molds, dies, presses and rolls which are to be heated.

Typical Applications Include:

Viscous fluids and other temperature sensitive materials such as adhesives, asphalt, chocolate, syrups and varnish found in tanks and process vessels.

Corrosive materials like acids and chemicals which would quickly corrode heating elements directly immersed in the material.

Platens, molds, presses or rolls found in plastic injection molding/extrusion processes, textile industries and food processing plants. Some systems may involve high temperatures and pressures.



Circulation Heaters

System Configurations (continued)

Direct Heating:

The process liquid or gas is recirculated directly through the heater in a closed loop system. Selecting the proper element watt density is very important. If the watt density is too high, the process fluid may carbonize or break down chemically.

Typical Applications Include:

Testing systems such as a test stand where the circulation heater is used to maintain uniform oil temperature during the testing of automobile engines. Laboratories and R & D centers have similar applications for a wide variety of liquids and gases.

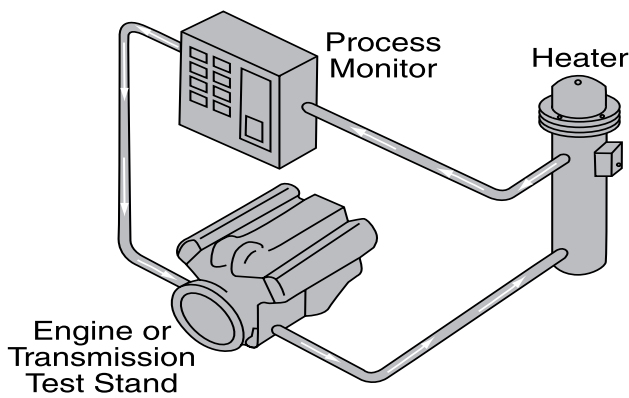

Drying systems where recirculated air or steam is heated or boosted to dry inks, textiles, bottles, pharmaceutical powders, cure parts or remove moisture from pressurized air systems.

Winter freeze protection for water tanks, cooling towers and sprinkler systems.

Diesel generator sets where cooling water and lubrication oil must be kept warm to assure fast start-up in cold weather.

Lubrication and hydraulic oil heating for maintaining the correct oil temperature and viscosity which is crucial for efficient operation of the pumps, transmission, engine or other equipment in the closed loop system.

Industrial processing tanks or baths which use the circulation heater to provide precise temperature control for oil quenching, cleaning tanks, rinsing tanks, degreasing tanks and water baths.

Advantages of circulation heater systems compared to direct immersion heaters for tank heating applications include:

- Heating elements are located away from areas of heavy sludge build-up or possible physical damage.
- Tank interior is kept open for process operations.
- Tank is easier to clean.
- Heater can be removed for inspection without draining the storage tank.

Open Heating Systems

The circulation heater is used in a system where the liquid or gas flows through the heater only once and is discharged directly into the application.

Typical Applications Include:

Booster heating systems which increase the temperature of the liquid, gas or steam just prior to being discharged directly into applications, such as steam cleaning, commercial dishwashers and high temperature process gas heating.

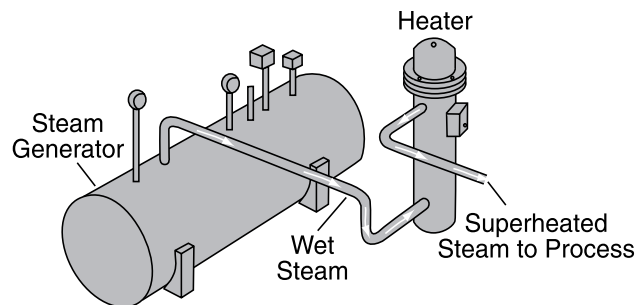

Fuel oil heating where the circulation heater raises the temperature of fuel oil to reduce its viscosity, facilitating its flow into the burner.

Spraying systems which use the heater to reduce viscosity or preheat the material before being pumped into a spray nozzle. For example, heavy petroleum is heated before it is sprayed over the top of coal to reduce dust and coal from being blown out of open railroad cars.

Engineering Information

Before selecting a standard circulation heater from the catalog listings, or customizing a design with any of the options and accessories, check the engineering information to assure proper heater design and performance for your application.

Calculating KW Requirements

When calculating the power required to heat a material flowing through the circulation heater, the KW equation shown below can be applied. This equation is based on the criteria that there is no vaporization occurring in the heater. The KW equation incorporates a 20% safety factor, allowing for heat losses of the jacket and piping, variation in voltage and wattage tolerance of the elements.

$$KW = \frac{M \times \Delta T \times Cp \times S.F.}{3412}$$

Where:

KW = power in kilowatts

M = flow rate in Lbs/Hr

ΔT = temperature rise in °F

(The difference between the minimum inlet temperature and maximum outlet temperature.)

Cp = specific heat in BTU/Lb °F

S.F. = safety factor, 1.2

3412 = conversion of BTU to KWH

Water Heating Example:

Application data: 8 GPM flow with an inlet temperature of 65° F and an outlet temperature of 95° F. First, convert the flow rate to Lbs/Hr.

$$\frac{8 \text{ Gal}}{\text{Min}} \times \frac{1 \text{ Ft}^3}{7.48 \text{ Gal}} \times \frac{60 \text{ Min}}{1 \text{ Hr}} = 64.17 \text{ Ft}^3/\text{Hr}$$

Obtain the specific heat (Cp) and density from Table III, page 7.

$$64.17 \text{ Ft}^3/\text{Hr} \times 62.4 \text{ Lbs}/\text{Ft}^3 = 4004 \text{ Lbs}/\text{H}$$

Now calculate KW:

$$KW = \frac{4004 \text{ Lbs}/\text{Hr} \times (95-65)^\circ\text{F} \times 1 \text{ BTU}/\text{Lbs}^\circ\text{F} \times 1.2}{3412}$$

$$KW = 42$$

Oil Heating Example:

Application data: SAE 30 lubrication oil with a flow rate of 135 GPM, an inlet temperature of 45° F and an outlet temperature of 55° F. First, convert the flow rate to Lbs/Hr.

$$\frac{135 \text{ Gal}}{\text{Min}} \times \frac{1 \text{ Ft}^3}{7.48 \text{ Gal}} \times \frac{60 \text{ Min}}{1 \text{ Hr}} = 1083 \text{ Ft}^3/\text{Hr}$$

Obtain the specific heat (Cp) and density from Table III.

$$1083 \text{ Ft}^3/\text{Hr} \times 55.4 \text{ Lbs}/\text{Ft}^3 = 60,000 \text{ Lbs}/\text{Hr}$$

Now calculate KW:

$$KW = \frac{60,000 \text{ Lbs}/\text{Hr} \times (55-45)^\circ\text{F} \times .45 \text{ BTU}/\text{Lbs}^\circ\text{F} \times 1.2}{3412}$$

$$KW = 95$$

Gas Heating Example:

Application data: Air is flowing at 187 ACFM and 5 PSIG pressure. The inlet temperature of the air is 90° F and the outlet temperature is 250° F. First, convert the flow rate to SCFM.

$$SCFM = ACFM \times \frac{PSIA}{14.7 \text{ PSIA}} \times \frac{530^\circ\text{R}}{(T^\circ\text{F}+460^\circ\text{R})}$$

Where:

T = Inlet temperature in °F

ACFM = Actual cubic feet per minute (This is the actual volume flow rate value at inlet temperature and operating pressure, PSIA.)

SCFM = Standard cubic feet per minute (This is the volume flow rate value at 70° F and atmospheric pressure, 14.7 PSIA.)

PSIA = Pounds per square inch, absolute

PSIG = Pounds per square inch, gauge

PSIA = PSIG + 14.7 (Note: If value is given as psi, it is implied to be PSIG.)

$$187 \text{ ACFM} \times \frac{19.7 \text{ PSIA}}{14.7 \text{ PSIA}} \times \frac{530^\circ\text{R}}{(90^\circ\text{F}+460^\circ\text{R})} = \text{SCFM}$$

$$241.5 = \text{SCFM}$$

Now convert to Lbs/Hr.

$$241.5 \text{ SCFM} \times \frac{60 \text{ Min}}{1 \text{ Hr}} \times \frac{.073 \text{ Lbs}}{\text{Ft}^3} = 1057.7 \text{ Lbs}/\text{Hr}$$

Reference Table I for the density and specific heat (Cp) of air.

Circulation Heaters

Engineering Information (continued)

Properties for Gases

Table I

Gas	Density (Lbs/Ft ³)	Specific Heat (BTU/Lb °F)
Air	0.073	0.24
Nitrogen	0.073	0.25
Steam	0.037	0.49

Densities and specific heats are at atmospheric pressure (14.7 PSIA) and 70° F, except the temperature for steam is 212° F.

Now calculate KW: (Specific heat of air at average temperature of 170° F is also .24.)

$$KW = \frac{1057.7 \text{ Lbs/Hr} \times (250-90)^\circ\text{F} \times 0.24 \text{ BTU/Lbs}^\circ\text{F} \times 1.2}{3412}$$

$$KW = 14.3$$

Pressure Drop

Pressure drop through the heater is a function of many variables, including type of liquid or gas, flow rate, temperature and vessel size. Use the information on this page as a guideline for common applications where water, lube oil, fuel oil, or ethylene glycol are heated from 60° F. For other applications, including heating gases, contact Heatrex, and we will determine the pressure drop for you.

The curves on Chart A indicate the pressure drop for the different diameters of catalog listed heaters. The curves are based on water at 60° F, and the heaters having the standard inlet and outlet sizes as listed on page 10.

Table II gives correction factors for Chart A when these other liquids are being heated from 60° F.

Pressure Drop Correction Factors

Table II

Liquid	Correction Factor
SAE 30 Lubrication Oil	1.6
No. 2 Fuel Oil	1.4
Ethylene Glycol (50% Solution)	1.7

Example:

Flow rate: 100 GPM

Liquid: SAE 30 lubrication oil

Inlet Temperature: 60° F

First, select the vessel size by determining the KW rating and watt density and referring to the oil heater listings. For this example, we will select a 5" flange heater.

From the water pressure drop curves, we get a 2 psi pressure drop, then we multiply that value by the correction factor for SAE 30 lubrication oil. This gives a 3.2 psi pressure drop through the heater for this application.

The viscosity of oil can change dramatically with a 30° F change in temperature. If your inlet temperature is different than 60° F, or the graphs indicate a pressure drop is too high for your system, please contact Heatrex. We can evaluate your exact requirements and offer alternatives to meet your needs.

Chart A

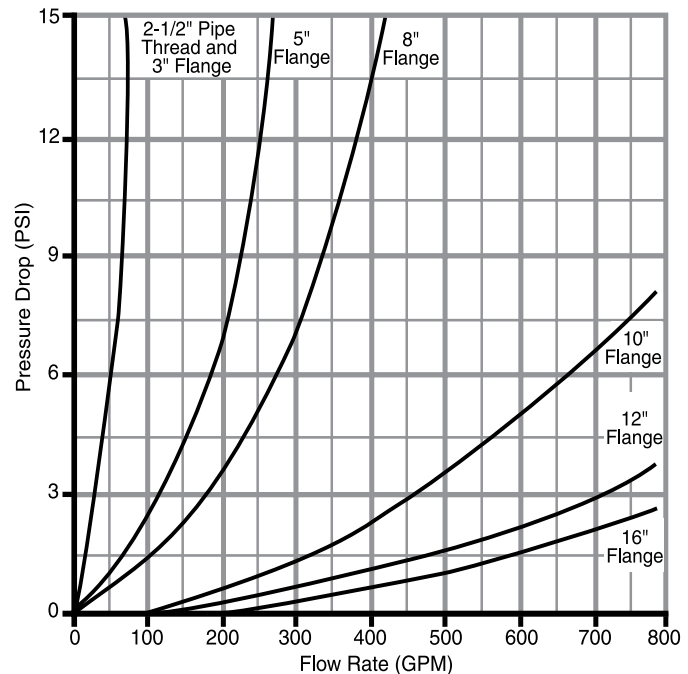

Circulation Heaters

Watt Density and Element Sheath Material Selection

Selecting the proper watt density (watts per square inch of element surface area) and the proper sheath material is critical to heater life and fluid integrity. If the watt density is too high, the fluid may carbonize, break down chemically, or the elements may burn out. If the sheath material selection is incorrect, it will corrode, destroying the element.

In general, watt density is determined by three factors:

- 1) maximum outlet temperature
- 2) type of fluid heated and
- 3) fluid flow rate.

Sheath material depends on the type of fluid and maximum temperature.

The standard vessel material is carbon steel. A stainless steel vessel may be required at higher temperatures or for better corrosion resistance.

Table III gives watt densities and sheath material guidelines for a variety of liquids.

The watt density and sheath material guidelines shown in this table should not be interpreted as a recommendation for all applications because there are many other factors that can affect the selection of the appropriate watt density or sheath material. Use this information as an initial guide along with knowledge of the actual conditions which exist in the heating application.

Maximum Watt Densities, Sheath Materials and Properties for Liquids

Table III

Liquid	Max. Fluid Temp. (°F)	Max. Watt Density (W/In ²)	Density ⁽¹⁾ (Lbs/Ft ³)	Specific ⁽¹⁾ Heat, Cp (BTU/Lbs °F)	Sheath Materials			
					Copper	Steel	Stainless Steel	Incoloy
Acetic Acid ⁽²⁾	221	40	65.4	0.51			C	C
Alkaline Solutions	212	50	62.0	1.00			B	
Asphalt	500	6	132.0	0.22		A	A	A
Ethylene Glycol-50% Solution	300	50	65.8	0.76	A	B	A	A
Fuel Oils								
No. 1*	575	20	50.5	0.50	A	A	A	
No. 2	375	20	53.9	0.47	A	A	A	
No. 5	375	12	58.9	0.45	A	A	A	
No. 6	375	8	58.9	0.44	A	A	A	
Heat Transfer Oils								
Caloria HT 43	475	12	52.0	0.43	A	A	A	
Chemtherm 660	675	20	63.7	0.38	A	A	A	
Dowtherm A	725	20	66.0	0.38	A	A	A	
Dowtherm G	675	20	68.6	0.37	A	A	A	
Dowtherm HT	625	20	60.6	0.37	A	A	A	
Dowtherm J	575	20	54.1	0.43	A	A	A	
Dowtherm LF	575	20	63.0	0.40	A	A	A	
Hitec	875	20	126.2	0.37	A	A	A	
Marlotherm L	675	20	58.7	0.45	A	A	A	
Marlotherm S	675	12	60.8	0.43	A	A	A	
Mobiltherm 600	550	20	58.4	0.43	A	A	A	
Mobiltherm 603	550	20	53.9	0.44	A	A	A	
Mobiltherm 605	550	20	53.9	0.44	A	A	A	
Mobiltherm Light	550	20	61.3	0.42	A	A	A	
Multitherm PG-1	565	12	54.2	0.45	A	A	A	
Multitherm IG-2	575	20	54.8	0.47	A	A	A	
Heat Transfer Oils								
Syltherm XLT	475	12	52.6	0.40			A	A A
Syltherm 800	725	12	58.7	0.38			A	A A
Thermalane 600	575	12	50.7	0.52			A	A A
Thermalane 800	675	12	50.1	0.57			A	A A
Therminol 44	400	12	57.8	0.47			A	A A
Therminol 55	560	12	55.2	0.46			A	A A
Therminol 59	575	20	60.6	0.41			A	A A
Therminol 60	560	20	62.6	0.39			A	A A
Therminol 66	630	20	63.0	0.38			A	A A
Therminol 75	675	20	68.8	0.38			A	A A
Therminol FR-1	575	20	85.5	0.28			A	A A
Therminol LT	475	20	53.7	0.43			A	A A
Therminol VP-1	725	20	66.7	0.37			A	A A
UCON 500	475	12	64.8	0.47			A	A A
Machine or Lubrication Oils								
SAE 10	275	20	55.4	0.45			A	A A
SAE 20	280	20	55.4	0.45			A	A A
SAE 30	285	20	55.4	0.45			A	A A
SAE 40	290	12	55.4	0.45			A	A A
SAE 50	295	12	55.4	0.45			A	A A
Vegetable Oil	380	30	50.6	0.58				A A
Water								
Process	212	50-80	62.4	1.00	A		A	A
Deionized ⁽²⁾	212	50-80	62.4	1.00			B	

(1) Densities and specific heats are at or near room temperature.

(2) Stainless steel vessel may be required.

* Kerosene

Rating legend:

A – Good

B – Fair

C – Conditional, solution concentration and temperature will affect suitability.



Circulation Heaters

Dimensional Drawings

Figure 1
2-1/2" Pipe Thread Construction

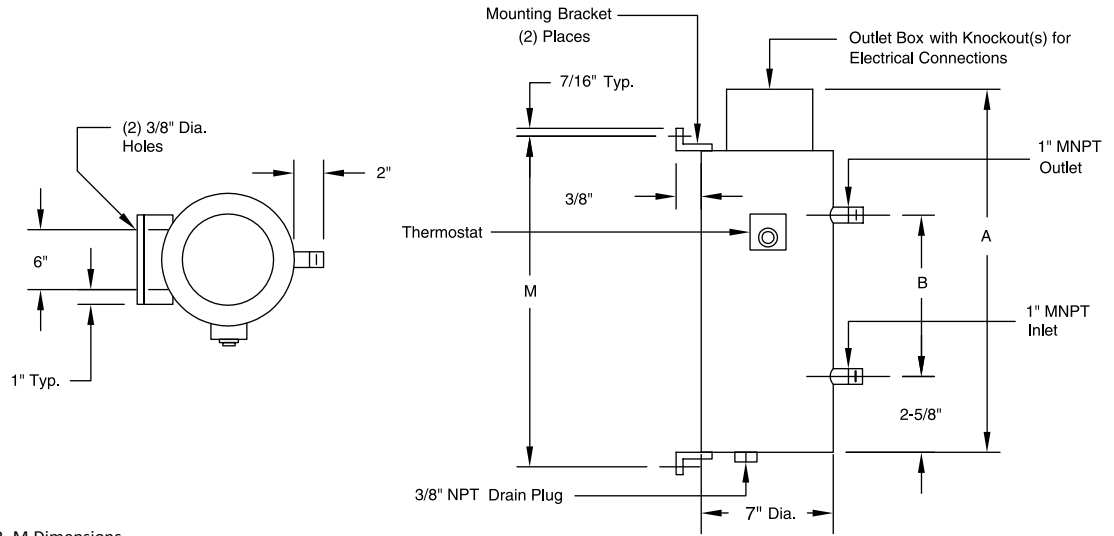

See pages 18-24 for A, B, M Dimensions

Figure 2
3", 5" & 8" Flange Construction

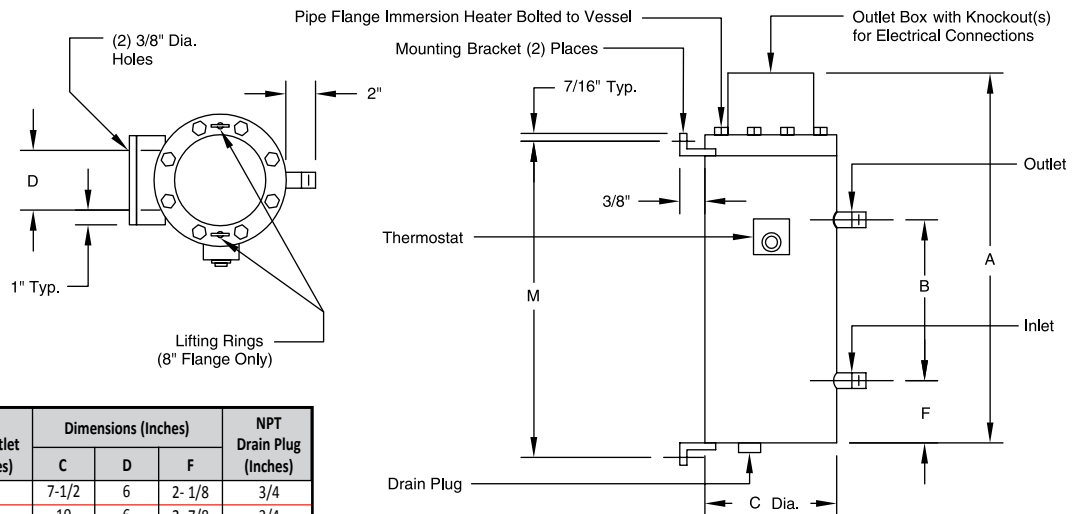

Flange Size (Inches)	MNPT Standard Inlet/Outlet Nozzle Size (Inches)	Dimensions (Inches)			NPT Drain Plug (Inches)
		C	D	F	
3	1	7-1/2	6	2-1/8	3/4
5	2	10	6	2-7/8	3/4
8	2-1/2	13-1/2	9	7	1

See pages 18-24 for A, B, M Dimensions

Figure 3
10", 12" & 16" Flange Construction

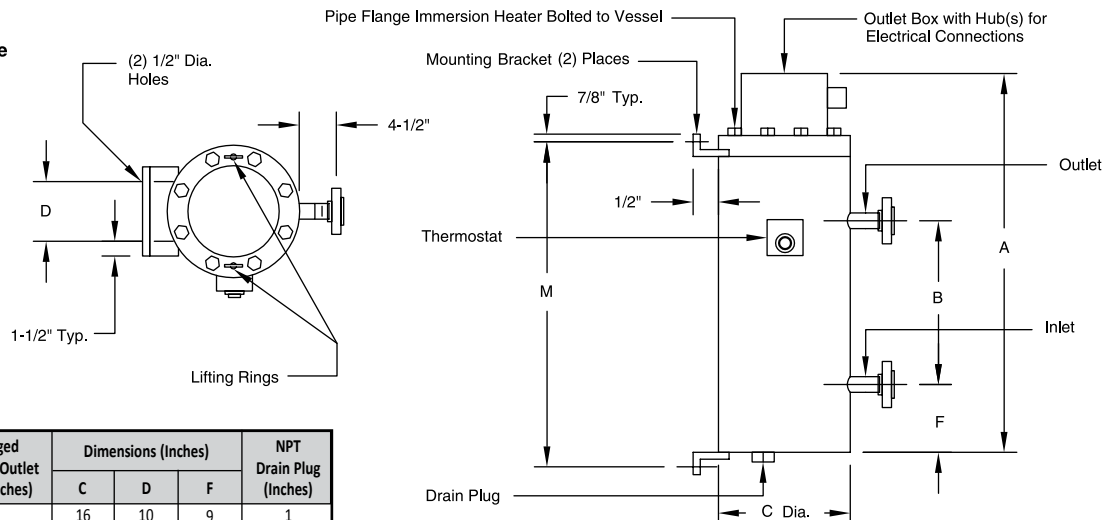

Flange Size (Inches)	150 lb. Flanged Standard Inlet/Outlet Nozzle Size (Inches)	Dimensions (Inches)			NPT Drain Plug (Inches)
		C	D	F	
10	3	16	10	9	1
12	6	19	12	10	1-1/2
16	6	23-1/2	15	11	1-1/2

See pages 16-22 for A, B, M Dimensions

Circulation Heaters

Mounting Options

Figure 4
Vertical Wall Mounting

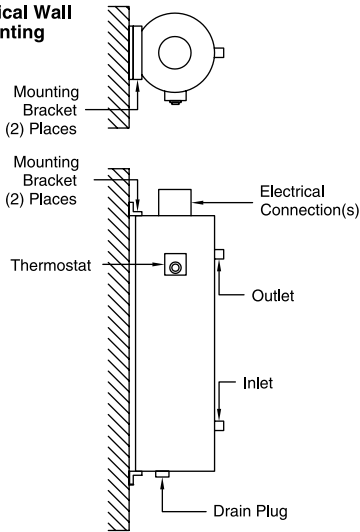

Figure 6
Horizontal Wall Mounting

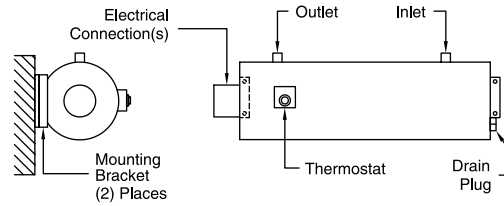

Figure 5
Vertical Floor Mounting

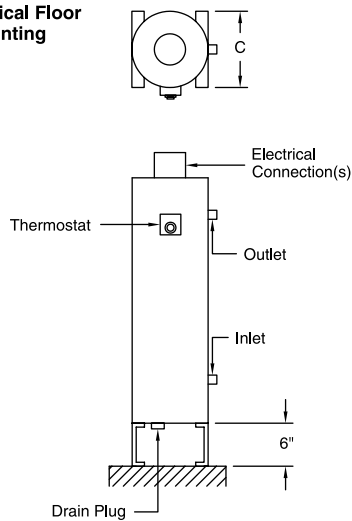

Figure 7
Horizontal Floor Mounting

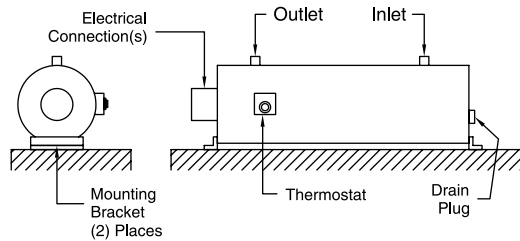
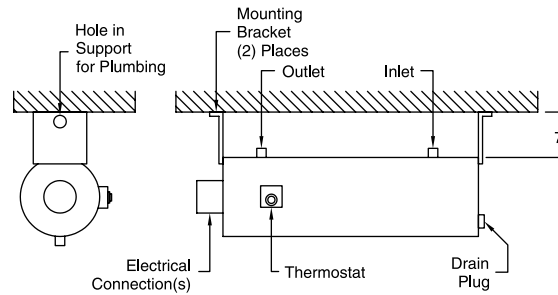
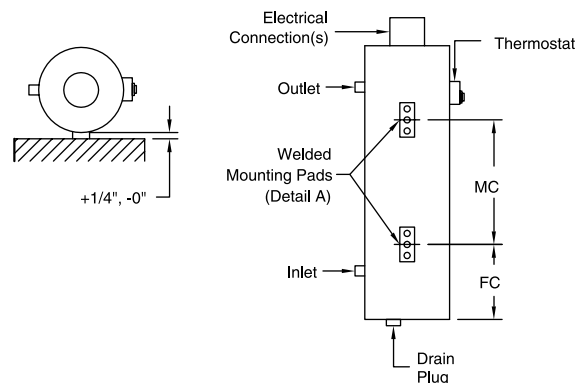

Figure 8
Horizontal Ceiling Mounting



Not available for 8" flange heaters and larger.

Figure 9
Mounting Pads



Detail A

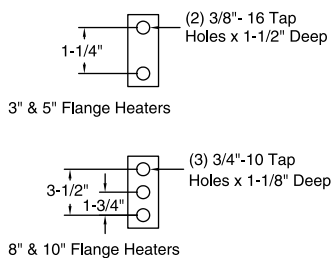

Not available for 10" flange heaters and larger.
Note: Thermostat must always be in a vertical position.
Specify if horizontal heater mounting is required.

Circulation Heaters

Mechanical and Electrical Guidelines

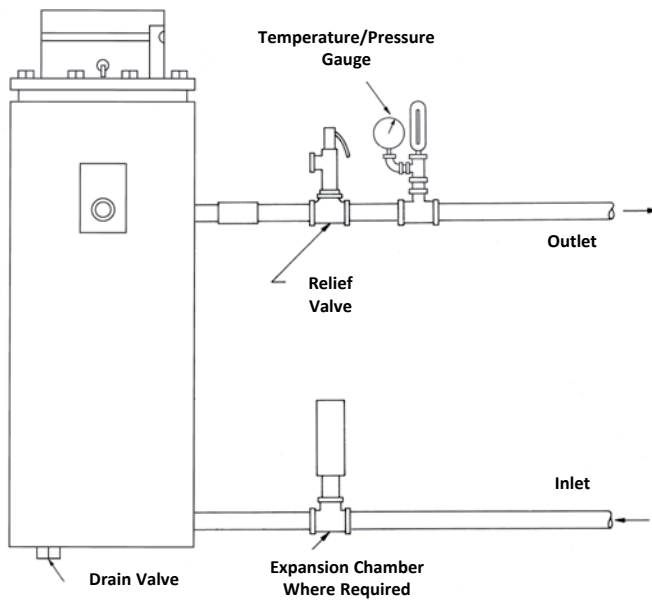

Review the following mechanical and electrical guidelines to specify the best heater design to meet your installation and performance requirements.

Mechanical and Plumbing

Heatrex offers six mounting options. Be sure to specify the appropriate mounting configuration for your application. Consider how you will install the heater and make the plumbing and electrical connections. Leave room for the pull space required to remove the immersion heater from the vessel for inspection, cleaning or replacement.

Verify that the standard circulation heater inlet/outlet location, size and type are appropriate for your installation.

Circulation heaters are designed to heat a fluid or gas as it flows through the vessel. These units are not intended to be used as storage tanks.

When a circulation heater is installed in a pressurized system, a relief valve must be installed in the outlet line. Heatrex can supply a pressure relief valve either built-on or as a loose accessory for field installation.

Do not place a shutoff of any type between the pressure relief valve and the circulation heater or on the discharge pipes between the relief valve and the atmosphere.

A drain plug is furnished in each vessel for periodic sludge removal and maintenance. A gate valve should be specified if frequent draining is required.

When the piping system includes a fast-acting valve or check valve, a customer supplied expansion chamber is recommended.

Adequate provision should be made for expansion and contraction of piping connected to the circulation heater.

The standard circulation heater construction is not designed for wet or hazardous locations. For these applications, a moisture and/or explosion-resistant construction, and a weather-proof insulation jacket are required.

Electrical

The standard circulation heater construction includes a factory-mounted, single stage, Type DA thermostat. This device is available in both two and three-pole models which have the following load carrying capacities:

Table IV

Voltage	Single-Phase (KW)	Three-Phase (KW)
120	3.6	—
208	6.2	10.8
240	7.2	12.4
277	8.3	—
480	9.6	—

Heaters rated above these capacities require a magnetic contactor, with the pilot duty DA thermostat controlling the contactor holding coil. Heatrex offers a convenient built-on contactor option. Figures 10 and 11 show typical wiring diagrams for both a load carrying thermostat and pilot duty thermostat with contactor either supplied by the customer in a remote panel, or built-on to the heater by Heatrex. Note that one contactor is required for each heater stage when optional two-stage thermostat is specified.

A Type DA thermostat must always be mounted in a vertical plane, never “on its back”, so be sure to specify the correct heater mounting configuration to assure the thermostat will be correctly oriented and factory-mounted.

Heatrex recommends some type of process overtemperature protection for all circulation heater systems. Options include:

- Built-on Type EC thermostat.
- Built-in thermocouple for remote process overtemperature controller.
- Pump interlock, if a chance exists the heater could be energized with no flow, such as built-in or customer field-installed flow switch or field-installed pump interlock relay.

Circulation Heaters

High limit protection can be provided to prevent element overheating and burnout due to low liquid level, inadequate flow, sludge build-up, etc. You should specify a built-in thermocouple for a remote high limit controller, page 15, or a low liquid level cutoff built-in or field installed, page 17.

The size and type of incoming field wiring will depend on maximum outlet temperature, heater current draw, and number of heater stages. Contact Heatrex for help in selecting the appropriate wire size per current NEC guidelines.

Heatrex heaters are designed and tested to provide +5%/-10% KW at rated voltage. KW at other than rated voltage is calculated as follows:

$$\text{New KW} = \frac{(\text{New Voltage})^2}{(\text{Rated Voltage})^2} \times \text{Rated KW}$$

Figure 12 shows a circulation heater system wiring diagram with heater, pump and control panel which includes controlling thermostat, high limit protection, controlling contactor, pump motor starter interlock, flow switch with time delay relay, circuit fusing, transformer and power disconnect switch.

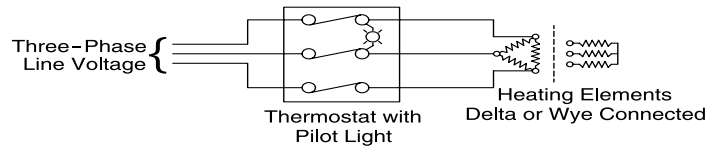

Figure 10

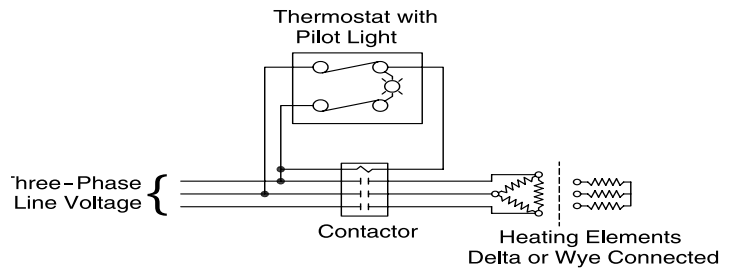

Figure 11

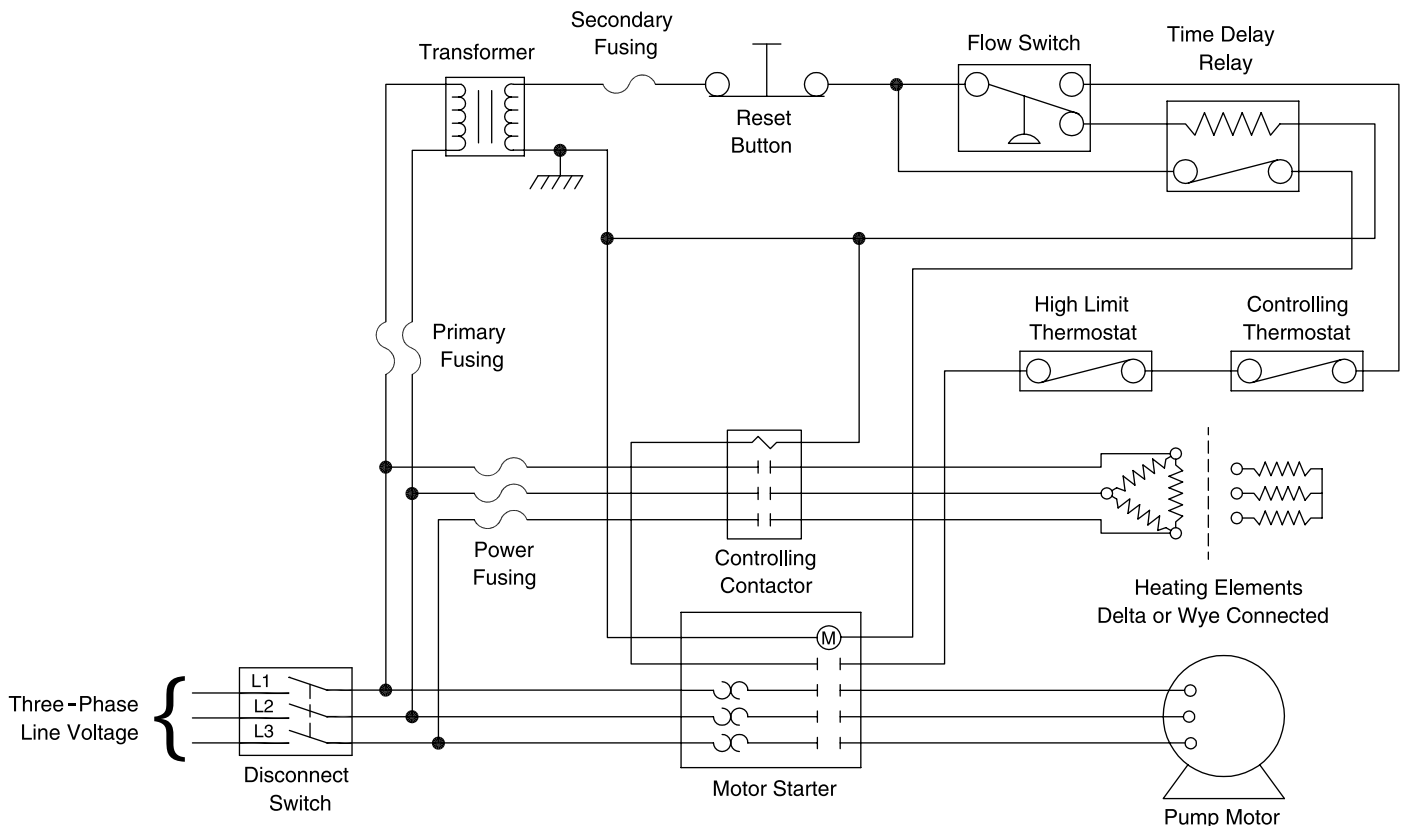

Figure 12

Circulation Heaters

Special Features

Optional Built-On Thermostats and Contactors

Alternate Temperature Ranges for Standard Type DA Thermostat

- 0-100° F
- 200-550° F
- 300-700° F



Optional Type P Indicating and Two-Stage Thermostats

Stages	Process Temperature Ranges
1 or 2	20 - 120° F
1 or 2	50 - 250° F
1 or 2	100 - 650° F
1 or 2	100 - 1000° F

Tamperproof Thermostat Enclosure – Type DA thermostat is completely enclosed in a box with solid cover.



Type EC Thermostat for Process Overtemperature Protection – This field-adjustable thermostat acts as an automatic reset cutout to protect against process overtemperature. The sensing bulb is factory-mounted in the outlet area.

- Overtemperature Ranges:
- 60-250° F
- 150-550° F

No Built-On Thermostat – A built-on thermostat is not required because process temperature is controlled by remote thermostat or control panels.

Built-On Contactors – Magnetic contactors, required for use with built-on pilot duty thermostats, can be factory-mounted on the circulation heater, eliminating the need for a remote contactor enclosure and the associated field wiring costs.



Circulation Heaters

Built-In Thermocouple/RTD

A built-in Type J or K sheathed thermocouple can be provided for three specific purposes:

- **Process Temperature Control** – The thermocouple is factory-mounted in the outlet area to sense temperature for the process controller.
- **Process Overtemperature Protection** – The thermocouple is factory-mounted in the outlet area to sense temperature for the process overtemperature controller, which prevents process liquid or gas overheating.
- **Heater High Limit Protection** – The thermocouple is attached to the heating element to sense sheath temperature for the heater high limit controller. This prevents element overheating and burnout due to low liquid level, inadequate flow, sludge buildup, etc.

Special Sensors – Heatrex provides a wide range of special thermocouple, RTD and thermistor sensors to meet your temperature control requirements.

Temperature Control Panels – Control panels, designed and manufactured by Heatrex, offer a convenient, reliable means of completing the heater control package. Control panels containing all necessary components, such as contactors, fuses, transformer, disconnect switch, pilot lights and electronic controls are available. See pages 24-26.

Heatrex offers built-on, skid-mounted or remote temperature control panels with control components built into NEMA 4, NEMA 4X, NEMA 7 and NEMA 12 enclosures.

ASME Code Stamp – Heatrex has in-house ASME code welding capabilities. All Heatrex circulation heaters are designed in accordance with ASME standards. An ASME code stamp is optional.

ASME Code	Stamp	Description
VIII	“U”	Unfired pressure vessel for all other liquids and gases. ASME code places no restrictions on maximum working temperature or pressure.

Moisture and/or Explosion-Resistant Construction –

Recommended for applications where there is danger of moisture entering the terminal and thermostat enclosures (NEMA 4 construction) or for hazardous locations classified by the National Electrical Code as Class I, Divisions 1 & 2, Groups B, C & D (NEMA 7 construction).



For all moisture and/or explosion-resistant constructions, the externally mounted, built-on Type DA thermostat is replaced by a pilot duty, 60-250° F thermostat built into the terminal enclosure. Remote temperature control is required for temperatures above 250° F.

Weatherproof Insulation Jacket – A sealed, galvanized steel construction is recommended for most outdoor installations. Stainless steel construction is also available for high temperature, very wet or corrosive applications.

Circulation Heaters

Special Features (continued)

High Temperature Construction Features

Extended Terminal Enclosure – This terminal enclosure allows the use of 90° C rated incoming field wiring and epoxy element seals when the outlet temperature exceeds 400° F for gases or 450° F for liquids.

Ceramic Fiber Vessel Insulation – Ceramic fiber vessel insulation should be used when the outlet temperature exceeds 800° F.

Spiral-Wound Gasket – Spiral-wound, Type 304 stainless steel gaskets are recommended for extremes in joint relaxation, temperature or pressure cycling, shock or vibration. Spiral-wound gaskets are required when the outlet temperature exceeds 650° F for gases or 750° F for liquids. They are also recommended for fluids with low surface tension.

Special Mounting Brackets and Jacket Support – This option is required when the outlet temperature exceeds 400° F for gases or 450° F for liquids. One of the angle iron mounting brackets will have slotted holes and the vessel jacket will be supported in one location on a band. This allows for vessel expansion and contraction without heater damage.

Inlet/Outlet Variations

Special Inlet/Outlet Locations – The following configurations are available:

- Inlet/Outlet positioned 180° apart.
- Inlet/Outlet both rotated 180° from standard position.
- Inlet/Outlet located on heater bottom.

Special Ratings

Three types of special ratings are available:

Wattage – Custom designed heaters with non-standard kilowatt (KW) ratings and watt densities are available to meet your specific heating requirements. Special watt densities are often required for certain fluids and gases. See page 7.

Voltage - Any voltage is available up to 600 volts including 120, 208, 277, 380, 400, 415, 440, 480 and 600 volt ratings for custom designed heaters.

Pressure – Custom designs are available for pressures above the standard 160 psi rating at 250° F.

Special Materials

Vessel and Flanges – Special vessel and flange materials, including stainless steel, Incoloy and copper-nickel alloys can be specified for custom designs.

Heating Elements – Copper, Incoloy, Inconel, Monel, steel, 304 and 316 stainless steel sheath materials are readily available for both catalog and custom designs. Consult factory for availability of other special sheath materials.

Hermetic Terminal End Seals – For applications where an absolute moisture seal is required. Each element is fitted with ceramic-to-metal hermetic seals which are air-tight.

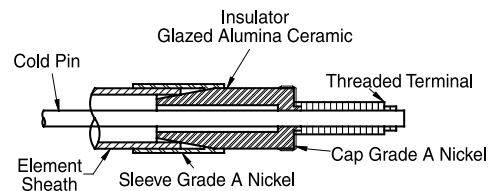

Vessel Sizes – Custom vessel designs are available from 1" to over 24" to accommodate larger KW requirements.

Accessories – Specify Built-In or Loose for Field Installation

Drain Valve – A gate valve is installed in the tank bottom. A drain plug is furnished as standard when a valve is not specified.

Pressure Relief Nozzle – A threaded nozzle can be built into the heater vessel for a customer-supplied, field-installed pressure relief valve.

Pressure Relief Valve – Sized for thermal relief, this valve is used to relieve excess pressure should unsafe conditions develop.



Low Liquid Cutoff – A safety device used to disconnect the heater if the liquid drops below a safe level. The cutoff consists of two components: A 316 stainless steel probe to sense liquid level and a pilot relay which de-energizes contactor holding coils. The heater automatically comes back on when the liquid level rises.

Low liquid cutoffs are available for:

- Water and other conducting liquids
- Oil and other non-conducting liquids



Flow Switch – This safety device prevents the heater from coming on unless the fluid is flowing. It requires field wiring to the control circuit.

Pressure Gauge – The standard range is 0-200 psi. Other pressure ranges are available.

Thermometer – This glass tube, liquid-filled thermometer is used to sense process outlet temperature.

Pump Interlock Relay – A safety device which prevents the heater from coming on unless the pump starter is closed. This double-pole, single-throw, normally open relay is field wired in parallel with the pump starter.

Circulation Heaters

Multi-Purpose Heater Listings

The Series HX-352 (12 W/In²), HX-354 (20 W/In²) and HX-356 (50 W/In²) Heatrex circulation heaters are designed for heating gases, water and oil. These high quality Multi-Purpose Heaters include the following standard features:

- Incoloy sheathed .475" diameter heating elements
- Insulated steel vessel with a galvanized jacket
- NEMA Type 1 terminal enclosure
- Built-on thermostat, 60-250° F range
- Choice of mounting brackets or mounting pads
- Flange heaters have Class 150 steel flanges which meet ANSI B16.5 standards
- Rated 160 psi at 250° F

Pad Mounting

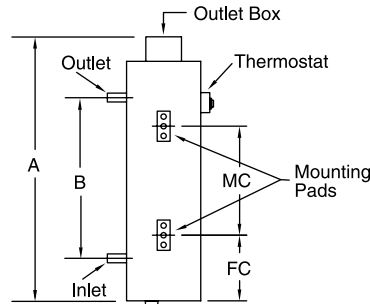

Bracket Mounting

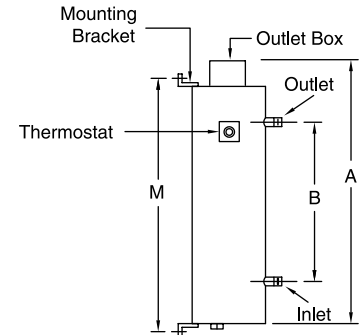

Reference Dimensional Drawings on page 8. Specify Mounting Configuration per page 9.

KW	Number Of Elements	Catalog Number**			Dimensions (Inches)					Weight (Lbs.)
		240V/1 Phase	240V/3 Phase	480V/3 Phase	A	B	MC	FC	M	
2 -1/2" PIPE THREAD CONSTRUCTION, INCOLOY ELEMENTS, 12 W/IN²										
2	2	HX-3522A002J01*			40-3/8	28-1/2	22-1/2	5-5/8	37-5/8	41
3	3	HX-3522A003J01*	HX-3522A003K01*	HX-3522A003U01	40-3/8	28-1/2	22-1/2	5-5/8	37-5/8	48
4	2	HX-3522A004J01*			67-7/8	56	50	5-5/8	65-1/8	74
6	3	HX-3522A006J01*	HX-3522A006K01*	HX-3522A006U01	67-7/8	56	50	5-5/8	65-1/8	74
3" -150 LB. FLANGE CONSTRUCTION, INCOLOY ELEMENTS, 12 W/IN²										
3	3	HX-3523A003J01*	HX-3523A003K01*	HX-3523A003U01	46-1/4	34-1/2	26-1/2	4-1/8	42-1/4	81
6	3	HX-3523A006J01*	HX-3523A006K01*	HX-3523A006U01	68-3/4	57	51	4-1/8	64-3/4	108
5" -150 LB. FLANGE CONSTRUCTION, INCOLOY ELEMENTS, 12 W/IN²										
9	9	HX-3524A009J01*	HX-3524A009K01*	HX-3524A009U01	43-1/2	30	25	4-3/4	38-7/8	141
18	9	HX-3524A018J03	HX-3524A018K01	HX-3524A018U01	70	56-1/2	25	18-1/4	65-3/8	200
8" -150 LB. FLANGE CONSTRUCTION, INCOLOY ELEMENTS, 12 W/IN²										
24	24	HX-3525A024J04	HX-3525A024K02	HX-3525A024U01	53-3/8	34-1/2	31	8-3/4	47-1/2	322
36	18		HX-3525A036K02	HX-3525A036U01	75-5/8	56-7/8	53-5/16	8-3/4	69-3/4	399
48	24		HX-3525A048K04	HX-3525A048U02	75-5/8	56-7/8	53-5/16	8-3/4	69-3/4	419
54	18		HX-3525A054K03	HX-3525A054U02	103-3/8	84-1/2	81	8-3/4	97-1/2	511
72	24		HX-3525A072K04	HX-3525A072U02	103-3/8	84-1/2	81	8-3/4	97-1/2	540
12" -150 LB. FLANGE CONSTRUCTION, INCOLOY ELEMENTS, 12 W/IN²										
80	45		HX-3527N080K05	HX-3527N080U03	84	60	—	—	78-9/16	885
100	45			HX-3527N100U03	94	70	—	—	88-9/16	958
120	48			HX-3527N120U04	94	70	—	—	88-9/16	970
135	48			HX-3527N135U04	104	80	—	—	98-9/16	1043
16" -150 LB. FLANGE CONSTRUCTION, INCOLOY ELEMENTS, 12 W/IN²										
150	72			HX-3528N150U04	83-1/2	58	—	—	77-7/8	1110
175	72			HX-3528N175U06	93-1/2	68	—	—	87-7/8	1284
195	72			HX-3528N195U06	101-1/2	76	—	—	95-7/8	1398
2 -1/2" PIPE THREAD CONSTRUCTION, INCOLOY ELEMENTS, 20 W/IN²										
2.25	3	HX-3542A002J01*	HX-3542A002K01*		24-7/8	13	—	—	22-1/8	35
3	3	HX-3542A003J01*	HX-3542A003K01*	HX-3542A003U01	34-3/8	22-1/2	16-1/2	5-5/8	31-5/8	41
4.5	3	HX-3542A005J01*	HX-3542A005K01*	HX-3542A005U01	40-3/8	28-1/2	22-1/2	5-5/8	37-5/8	48
6	3	HX-3542A006J01*	HX-3542A006K01*	HX-3542A006U01	57-1/8	45-1/4	39-1/4	5-5/8	54-3/8	62

* Indicates factory wired, built-on load carrying thermostat. All other built-on thermostats are pilot duty only. Last two digits of catalog number indicate number of heater circuits.

** If any special features are added to a standard heater, the part number will change to a HX-350-Series number. This part number is assigned after an order is placed.

Circulation Heaters

KW	Number Of Elements	Catalog Number**			Dimensions (Inches)					Weight (Lbs.)
		240V/1 Phase	240V/3 Phase	480V/3 Phase	A	B	MC	FC	M	
3" -150 LB. FLANGE CONSTRUCTION, INCOLOY ELEMENTS, 20 W/IN²										
3.75	3	HX-3543A004J01*	HX-3544A014K01	HX-3543A004U01	34-1/4	22-1/2	16-1/2	4-1/8	30-1/4	65
6	3	HX-3543A006J01*	HX-3544A018K01	HX-3543A006U01	46-1/4	34-1/2	26-1/2	4-1/8	42-1/4	81
7.5	3	HX-3543A008J01*	HX-3544A024K02	HX-3543A008U01	56-3/4	45	39	4-1/8	52-3/4	93
12	3	HX-3543A012J03	HX-3544A036K03	HX-3543A012U01	79-3/4	68	62	4-1/8	75-3/4	101
5" -150 LB. FLANGE CONSTRUCTION, INCOLOY ELEMENTS, 20 W/IN²										
13.5	9	HX-3544A014J03	HX-3544A014K01	HX-3544A014U01	43-1/2	30	25	4-3/4	38-7/8	140
18	9	HX-3544A018J03	HX-3544A018K01	HX-3544A018U01	50-1/2	37	25	9	45-7/8	157
24	6	HX-3544A024J03	HX-3544A024K02	HX-3544A024U01	81-1/2	68	25	24	76-7/8	214
36	9		HX-3544A036K03	HX-3544A036U01	81-1/2	68	25	24	76-7/8	225
8" -150 LB. FLANGE CONSTRUCTION, INCOLOY ELEMENTS, 20 W/IN²										
45	18		HX-3545A045K03	HX-3545A045U02	66-1/8	47-3/8	43-13/16	8-3/4	60-1/4	361
54	18		HX-3545A054K03	HX-3545A054U02	69-3/8	50-1/2	47	8-3/4	63-1/2	373
72	18		HX-3545A072K06	HX-3545A072U02	86-3/8	67-1/2	64	8-3/4	80-1/2	443
96	24		HX-3545A096K08	HX-3545A096U04	86-3/8	67-1/2	64	8-3/4	80-1/2	466
10" -150 LB. FLANGE CONSTRUCTION, INCOLOY ELEMENTS, 20 W/IN²										
80	30		HX-3546N080K05	HX-3546N080U05	77	52	48-1/2	10-3/4	71-5/8	607
90	30		HX-3546N090K05	HX-3546N090U05	81	56	52-1/2	10-3/4	75-5/8	631
100	30		HX-3546N100K10	HX-3546N100U05	87	62	58-1/2	10-3/4	81-5/8	666
120	30		HX-3546N120K10	HX-3546N120U05	97	72	68-1/2	10-3/4	91-5/8	724
140	30		HX-3546N140K10	HX-3546N140U05	105	80	76-1/2	10-3/4	99-5/8	772
12" -150 LB. FLANGE CONSTRUCTION, INCOLOY ELEMENTS, 20 W/IN²										
125	45			HX-3547N125U05	74	50	—	—	68-9/16	813
150	45			HX-3547N150U05	84	60	—	—	78-9/16	884
175	45			HX-3547N175U05	94	70	—	—	88-9/16	957
200	42			HX-3547N200U07	104	80	—	—	98-9/16	1016
16" -150 LB. FLANGE CONSTRUCTION, INCOLOY ELEMENTS, 20 W/IN²										
250	72			HX-3548N250U08	83-1/2	58	—	—	77-7/8	1110
300	72			HX-3548N300U08	93-1/2	68	—	—	87-7/8	1284
325	72			HX-3548N325U12	101-1/2	76	—	—	95-7/8	1398
2-1/2" PIPE THREAD CONSTRUCTION, INCOLOY ELEMENTS, 50 W/IN²										
3	3	HX-3562A003J01*	HX-3562A003K01*		21-1/4	9-3/8	—	—	18-1/2	30
4.5	3	HX-3562A005J01*	HX-3562A005K01*	HX-3562A005U01	21-1/4	9-3/8	—	—	18-1/2	30
6	3	HX-3562A006J01*	HX-3562A006K01*	HX-3562A006U01	34-3/8	22-1/2	16-1/2	5-5/8	31-5/8	40
7.5	3	HX-3562A008J01*	HX-3562A008K01*	HX-3562A008U01	34-3/8	22-1/2	16-1/2	5-5/8	31-5/8	41
9	3	HX-3562A009J01*	HX-3562A009K01*	HX-3562A009U01	34-3/8	22-1/2	16-1/2	5-5/8	31-5/8	41
3" -150 LB. FLANGE CONSTRUCTION, INCOLOY ELEMENTS, 50 W/IN²										
6	3	HX-3563A006J01*	HX-3563A006K01*	HX-3563A006U01	34-1/4	22-1/2	16-1/2	4-1/8	30-1/4	65
9	3	HX-3563A009J01*	HX-3563A009K01*	HX-3563A009U01	34-1/4	22-1/2	16-1/2	4-1/8	30-1/4	66
12	3	HX-3563A012J03	HX-3563A012K01*	HX-3563A012U01	46-1/4	34-1/2	26-1/2	4-1/8	42-1/4	81
15	3	HX-3563A015J03	HX-3563A015K01	HX-3563A015U01	56-3/4	45	39	4-1/8	52-3/4	91
18	3	HX-3563A018J03	HX-3563A018K01	HX-3563A018U01	56-3/4	45	39	4-1/8	52-3/4	93
5" -150 LB. FLANGE CONSTRUCTION, INCOLOY ELEMENTS, 50 W/IN²										
24	6	HX-3564A024J03	HX-3564A024K02	HX-3564A024U01	43-1/2	30	25	4-3/4	38-7/8	135
30	6		HX-3564A030K02	HX-3564A030U01	50-1/2	37	25	9	45-7/8	150
45	9		HX-3564A045K03	HX-3564A045U03	50-1/2	37	25	9	45-7/8	157
63	9			HX-3564A063U03	62	48-1/2	25	14	57-3/8	181
8" -150 LB. FLANGE CONSTRUCTION, INCOLOY ELEMENTS, 50 W/IN²										
72	18		HX-3565A072K06	HX-3565A072U02	53-3/8	34-1/2	31	8-3/4	47-1/2	302
96	24		HX-3565A096K08	HX-3565A096U04	53-3/8	34-1/2	31	8-3/4	47-1/2	312
126	18			HX-3565A126U06	66-1/8	47-3/8	43-13/16	8-3/4	60-1/4	361
144	18			HX-3565A144U06	75-5/8	56-7/8	53-5/16	8-3/4	69-3/4	396
180	18			HX-3565A180U06	86-3/8	67-1/2	64	8-3/4	80-1/2	443
240	27			HX-3565A240U08	86-3/8	67-1/2	64	8-3/4	80-1/2	466

* Indicates factory wired, built-on load carrying thermostat. All other built-on thermostats are pilot duty only. Last two digits of catalog number indicate number of heater circuits.

** If any special features are added to a standard heater, the part number will change to a 350-Series number. This part number is assigned after an order is placed.

Circulation Heaters

Stainless Steel Heater Listings

The Series HX-350 (12 W/In²), HX-357 (20 W/In²) and HX-358 (50 W/In²) Heatrex circulation heaters are designed for heating mildly corrosive liquids or pure water solutions. This design may also be used for heating gases or liquids to high temperatures with optional thermostat and high temperature construction described in the Special Features section. These high quality Stainless Steel Heaters include the following standard features:

- Incoloy sheathed .475" diameter heating elements
- Insulated 304 stainless steel vessel with a galvanized jacket
- NEMA Type 1 terminal enclosure
- Built-on thermostat, 60-250° F range
- Choice of mounting brackets or mounting pads
- Flange heaters have Class 150 stainless steel flanges which meet ANSI B16.5 standards
- Rated 160 psi at 250° F
- Optional 316 stainless steel construction
- Optional passivation

Pad Mounting

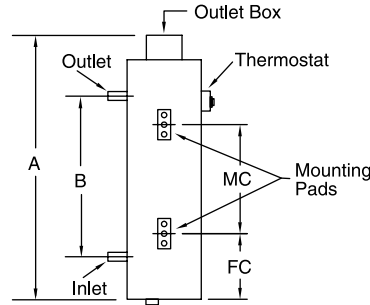

Bracket Mounting

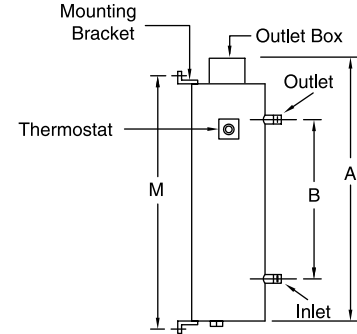

KW	Number Of Elements	Catalog Number**			Dimensions (Inches)					Weight (Lbs.)
		240V/1 Phase	240V/3 Phase	480V/3 Phase	A	B	MC	FC	M	
3" -150 LB. FLANGE CONSTRUCTION, INCOLOY ELEMENTS, 12 W/IN²										
3	3	HX-3503A003J01*	HX-3503A003K01*	HX-3503A003U01	46-1/4	34-1/2	26-1/2	4-1/8	42-1/4	70
6	3	HX-3503A006J01*	HX-3503A006K01*	HX-3503A006U01	68-3/4	57	51	4-1/8	64-3/4	91
5" -150 LB. FLANGE CONSTRUCTION, INCOLOY ELEMENTS, 12 W/IN²										
9	9	HX-3504A009J01*	HX-3504A009K01*	HX-3504A009U01	43-1/2	30	25	4-3/4	38-7/8	120
18	9	HX-3504A018J03	HX-3504A018K01	HX-3504A018U01	70	56-1/2	25	18-1/4	65-3/8	164
8" -150 LB. FLANGE CONSTRUCTION, INCOLOY ELEMENTS, 12 W/IN²										
24	24	HX-3505A024J04	HX-3505A024K02	HX-3505A024U01	53-3/8	34-1/2	31	8-3/4	47-1/2	265
36	18		HX-3505A036K02	HX-3505A036U01	75-5/8	56-7/8	53-5/16	8-3/4	69-3/4	314
48	24		HX-3505A048K04	HX-3505A048U02	75-5/8	56-7/8	53-5/16	8-3/4	69-3/4	334
54	18		HX-3505A054K03	HX-3505A054U02	103-3/8	84-1/2	81	8-3/4	97-1/2	391
72	24		HX-3505A072K04	HX-3505A072U02	103-3/8	84-1/2	81	8-3/4	97-1/2	420
12" -150 LB. FLANGE CONSTRUCTION, INCOLOY ELEMENTS, 12 W/IN²										
80	45		HX-3507N080K05	HX-3507N080U03	84	60	—	—	78-9/16	748
100	45			HX-3507N100U03	94	70	—	—	88-9/16	803
120	48			HX-3507N120U04	94	70	—	—	88-9/16	815
135	48			HX-3507N135U04	104	80	—	—	98-9/16	870
16" -150 LB. FLANGE CONSTRUCTION, INCOLOY ELEMENTS, 12 W/IN²										
150	72			HX-3508N150U04	83-1/2	58	—	—	77-7/8	1012
175	72			HX-3508N175U06	93-1/2	68	—	—	87-7/8	1173
195	72			HX-3508N195U06	101-1/2	76	—	—	95-7/8	1277
3"-150 lb. flange CONSTRUCTION, INCOLOY ELEMENTS, 20 W/IN²										
3.75	3	HX-3573A004J01*	HX-3573A004K01*	HX-3573A004U01	34-1/4	22-1/2	16-1/2	4-1/8	30-1/4	59
6	3	HX-3573A006J01*	HX-3573A006K01*	HX-3573A006U01	46-1/4	34-1/2	26-1/2	4-1/8	42-1/4	70
7.5	3	HX-3573A008J01*	HX-3573A008K01*	HX-3573A008U01	56-3/4	45	39	4-1/8	52-3/4	80
12	3	HX-3573A012J03	HX-3573A012K01*	HX-3573A012U01	79-3/4	68	62	4-1/8	75-3/4	101

* Indicates factory wired, built-on load carrying thermostat. All other built-on thermostats are pilot duty only. Last two digits of catalog number indicate number of heater circuits.

** If any special features are added to a standard heater, the part number will change to a HX-350-Series number. This part number is assigned after an order is placed.

Circulation Heaters

KW	Number Of Elements	Catalog Number**			Dimensions (Inches)					Weight (Lbs.)
		240V/1 Phase	240V/3 Phase	480V/3 Phase	A	B	MC	FC	M	
5" -150 LB. FLANGE CONSTRUCTION, INCOLOY ELEMENTS, 20 W/IN²										
13.5	9	HX-3574A014J03	HX-3574A014K01	HX-3574A014U01	43-1/2	30	25	4-3/4	38-7/8	120
18	9	HX-3574A018J03	HX-3574A018K01	HX-3574A018U01	50-1/2	37	25	9	45-7/8	132
24	6	HX-3574A024J03	HX-3574A024K02	HX-3574A024U01	81-1/2	68	25	24	76-7/8	172
36	9		HX-3574A036K03	HX-3574A036U01	81-1/2	68	25	24	76-7/8	183
8" -150 LB. FLANGE CONSTRUCTION, INCOLOY ELEMENTS, 20 W/IN²										
45	18		HX-3575A045K03	HX-3575A045U02	66-1/8	47-3/8	43-13/16	8-3/4	60-1/4	288
54	18		HX-3575A054K03	HX-3575A054U02	69-3/8	50-1/2	47	8-3/4	63-1/2	296
72	18		HX-3575A072K06	HX-3575A072U02	86-3/8	67-1/2	64	8-3/4	80-1/2	344
96	24		HX-3575A096K08	HX-3575A096U04	86-3/8	67-1/2	64	8-3/4	80-1/2	367
10" -150 LB. FLANGE CONSTRUCTION, INCOLOY ELEMENTS, 20 W/IN²										
80	30		HX-3576N080K05	HX-3576N080U05	77	52	48-1/2	10-3/4	71-5/8	483
90	30		HX-3576N090K05	HX-3576N090U05	81	56	52-1/2	10-3/4	75-5/8	500
100	30		HX-3576N100K10	HX-3576N100U05	87	62	58-1/2	10-3/4	81-5/8	524
120	30		HX-3576N120K10	HX-3576N120U05	97	72	68-1/2	10-3/4	91-5/8	564
140	30		HX-3576N140K10	HX-3576N140U05	105	80	76-1/2	10-3/4	99-5/8	597
12" -150 LB. FLANGE CONSTRUCTION, INCOLOY ELEMENTS, 20 W/IN²										
125	45			HX-3577N125U05	74	50	—	—	68-9/16	695
150	45			HX-3577N150U05	84	60	—	—	78-9/16	748
175	45			HX-3577N175U05	94	70	—	—	88-9/16	803
200	42			HX-3577N200U07	104	80	—	—	98-9/16	843
16" -150 LB. FLANGE CONSTRUCTION, INCOLOY ELEMENTS, 20 W/IN²										
250	72			HX-3578N250U08	83-1/2	58	—	—	77-7/8	1012
300	72			HX-3578N300U08	93-1/2	68	—	—	87-7/8	1173
325	72			HX-3578N325U12	101-1/2	76	—	—	95-7/8	1277
2-1/2" PIPE THREAD CONSTRUCTION, INCOLOY ELEMENTS, 50 W/IN²										
3	3	HX-3582A003J01*	HX-3582A003K01*		21-1/4	9-3/8	—	—	18-1/2	27
4.5	3	HX-3582A005J01*	HX-3582A005K01*	HX-3582A005U01	21-1/4	9-3/8	—	—	18-1/2	27
6	3	HX-3582A006J01*	HX-3582A006K01*	HX-3582A006U01	34-3/8	22-1/2	16-1/2	5-5/8	31-5/8	35
7.5	3	HX-3582A008J01*	HX-3582A008K01*	HX-3582A008U01	34-3/8	22-1/2	16-1/2	5-5/8	31-5/8	36
9	3	HX-3582A009J01*	HX-3582A009K01*	HX-3582A009U01	34-3/8	22-1/2	16-1/2	5-5/8	31-5/8	36
3" -150 LB. FLANGE CONSTRUCTION, INCOLOY ELEMENTS, 50 W/IN²										
6	3	HX-3583A006J01*	HX-3583A006K01*	HX-3583A006U01	34-1/4	22-1/2	16-1/2	4-1/8	30-1/4	58
9	3	HX-3583A009J01*	HX-3583A009K01*	HX-3583A009U01	34-1/4	22-1/2	16-1/2	4-1/8	30-1/4	59
12	3	HX-3583A012J03	HX-3583A012K01*	HX-3583A012U01	46-1/4	34-1/2	26-1/2	4-1/8	42-1/4	70
15	3	HX-3583A015J03	HX-3583A015K01	HX-3583A015U01	56-3/4	45	39	4-1/8	52-3/4	78
18	3	HX-3583A018J03	HX-3583A018K01	HX-3583A018U01	56-3/4	45	39	4-1/8	52-3/4	80
5" -150 LB. FLANGE CONSTRUCTION, INCOLOY ELEMENTS, 50 W/IN²										
24	6	HX-3584A024J03	HX-3584A024K02	HX-3584A024U01	43-1/2	30	25	4-3/4	38-7/8	114
30	6		HX-3584A030K02	HX-3584A030U01	50-1/2	37	25	9	45-7/8	125
45	9		HX-3584A045K03	HX-3584A045U03	50-1/2	37	25	9	45-7/8	132
63	9			HX-3584A063U03	62	48-1/2	25	14	57-3/8	150
8" -150 LB. FLANGE CONSTRUCTION, INCOLOY ELEMENTS, 50 W/IN²										
72	18		HX-3585A072K06	HX-3585A072U02	53-3/8	34-1/2	31	8-3/4	47-1/2	245
96	24		HX-3585A096K08	HX-3585A096U04	53-3/8	34-1/2	31	8-3/4	47-1/2	255
126	18			HX-3585A126U06	66-1/8	47-3/8	43-13/16	8-3/4	60-1/4	288
144	18			HX-3585A144U06	75-5/8	56-7/8	53-5/16	8-3/4	69-3/4	311
180	18			HX-3585A180U06	86-3/8	67-1/2	64	8-3/4	80-1/2	244
240	24			HX-3585A240U08	86-3/8	67-1/2	64	8-3/4	80-1/2	367

* Indicates factory wired, built-on load carrying thermostat. All other built-on thermostats are pilot duty only. Last two digits of catalog number indicate number of heater circuits.

** If any special features are added to a standard heater, the part number will change to a HX-350-Series number. This part number is assigned after an order is placed.



Circulation Heaters

Oil Heater Listings

The Series HX-351 (12 W/In²) and HX-353 (20 W/In²) Heatrex circulation heaters are designed for heating oil. These high quality Oil Heaters include the following standard features:

- Steel sheathed .475" diameter heating elements
- Insulated steel vessel with a galvanized jacket
- NEMA Type 1 terminal enclosure
- Built-on thermostat, 60-250° F range
- Choice of mounting brackets or mounting pads
- Flange heaters have Class 150 steel flanges which meet ANSI B16.5 standards
- Rated 160 psi at 250° F

Pad Mounting

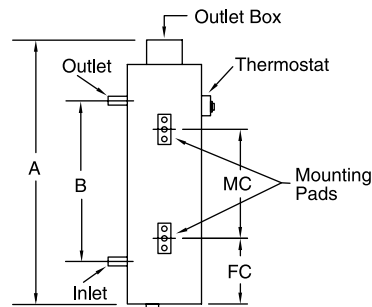

Bracket Mounting

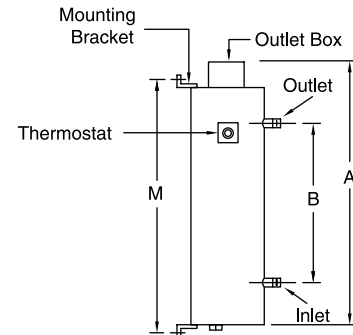

Reference Dimensional Drawings on page 8. Specify Mounting Configuration per page 9.

KW	Number Of Elements	Catalog Number**			Dimensions (Inches)					Weight (Lbs.)
		240V/1 Phase	240V/3 Phase	480V/3 Phase	A	B	MC	FC	M	
2-1/2" PIPE THREAD CONSTRUCTION, INCOLOY ELEMENTS, 12 W/IN²										
2	3	HX-3512N002J01*	HX-3512N002K01*		34-3/8	22-1/2	16-1/2	5-5/8	31-5/8	41
3	3	HX-3512N003J01*	HX-3512N003K01*	HX-3512N003U01	40-3/8	28-1/2	22-1/2	5-5/8	37-5/8	48
4	3	HX-3512N004J01*	HX-3512N004K01*	HX-3512N004U01	57-1/8	45-1/4	39-1/4	5-5/8	54-3/8	62
6	3	HX-3512N006J01*	HX-3512N006K01*	HX-3512N006U01	67-7/8	56	50	5-5/8	65-1/8	74
3" -150 LB. FLANGE CONSTRUCTION, INCOLOY ELEMENTS, 12 W/IN²										
3	3	HX-3513N003J01*	HX-3513N003K01*	HX-3513N003U01	46-1/4	34-1/2	26-1/2	4-1/8	42-1/4	81
6	3	HX-3513N006J01*	HX-3513N006K01*	HX-3513N006U01	68-3/4	57	51	4-1/8	64-3/4	108
5" -150 LB. FLANGE CONSTRUCTION, INCOLOY ELEMENTS, 12 W/IN²										
9	9	HX-3514N009J01*	HX-3514N009K01*	HX-3514N009U01	43-1/2	30	25	4-3/4	38-7/8	141
18	9	HX-3514N018J03	HX-3514N018K01	HX-3514N018U01	70	56-1/2	25	18-1/4	65-3/8	200
8" -150 LB. FLANGE CONSTRUCTION, INCOLOY ELEMENTS, 12 W/IN²										
24	24	HX-3515N024J04	HX-3515N024K02	HX-3515N024U01	53-3/8	34-1/2	31	8-3/4	47-1/2	322
36	18		HX-3515N036K02	HX-3515N036U01	75-5/8	56-7/8	53-5/16	8-3/4	69-3/4	399
48	24		HX-3515N048K04	HX-3515N048U02	75-5/8	56-7/8	53-5/16	8-3/4	69-3/4	419
54	18		HX-3515N054K03	HX-3515N054U02	103-3/8	84-1/2	81	8-3/4	97-1/2	511
72	24		HX-3515N072K04	HX-3515N072U02	103-3/8	84-1/2	81	8-3/4	97-1/2	540
12" -150 LB. FLANGE CONSTRUCTION, INCOLOY ELEMENTS, 12 W/IN²										
80	45		HX-3517N080K05	HX-3517N080U03	84	60	—	—	78-9/16	885
100	45			HX-3517N100U03	94	70	—	—	88-9/16	958
120	48			HX-3517N120U04	94	70	—	—	88-9/16	970
135	48			HX-3517N135U04	104	80	—	—	98-9/16	1043
16" -150 LB. FLANGE CONSTRUCTION, INCOLOY ELEMENTS, 20 W/IN²										
150	72			HX-3518N150U04	83-1/2	58	—	—	77-7/8	1110
175	72			HX-3518N175U06	93-1/2	68	—	—	87-7/8	1284
195	72			HX-3518N195U06	101-1/2	76	—	—	95-7/8	1398

* Indicates factory wired, built-on load carrying thermostat. All other built-on thermostats are pilot duty only. Last two digits of catalog number indicate number of heater circuits.

** If any special features are added to a standard heater, the part number will change to a HX-350-Series number. This part number is assigned after an order is placed.

Circulation Heaters

KW	Number Of Elements	Catalog Number**			Dimensions (Inches)					Weight (Lbs.)
		240V/1 Phase	240V/3 Phase	480V/3 Phase	A	B	MC	FC	M	
2-1/2" PIPE THREAD CONSTRUCTION, INCOLOY ELEMENTS, 20 W/IN²										
2.25	3	HX-3532N002J01*	HX-3532N002K01*		24-7/8	13	—	—	22-1/8	35
3	3	HX-3532N003J01*	HX-3532N003K01*	HX-3532N003U01	34-3/8	22-1/2	16-1/2	5-5/8	31-5/8	41
4.5	3	HX-3532N005J01*	HX-3532N005K01*	HX-3532N005U01	40-3/8	28-1/2	22-1/2	5-5/8	37-5/8	48
6	3	HX-3532N006J01*	HX-3532N006K01*	HX-3532N006U01	57-1/8	45-1/4	39-1/4	5-5/8	54-3/8	62
3" -150 LB. FLANGE CONSTRUCTION, INCOLOY ELEMENTS, 20 W/IN²										
3.75	3	HX-3533N004J01*	HX-3533N004K01*	HX-3533N004U01	34-1/4	22-1/2	16-1/2	4-1/8	30-1/4	65
6	3	HX-3533N006J01*	HX-3533N006K01*	HX-3533N006U01	46-1/4	34-1/2	26-1/2	4-1/8	42-1/4	81
7.5	3	HX-3533N008J01*	HX-3533N008K01*	HX-3533N008U01	56-3/4	45	39	4-1/8	53-3/4	93
12	3	HX-3533N012J03	HX-3533N012K01*	HX-3533N012U01	79-3/4	68	62	4-1/8	75-3/4	101
5" -150 LB. FLANGE CONSTRUCTION, INCOLOY ELEMENTS, 20 W/IN²										
13.5	9	HX-3534N014J03	HX-3534N014K01	HX-3534N014U01	43-1/2	30	25	4-3/4	38-7/8	140
18	9	HX-3534N018J03	HX-3534N018K01	HX-3534N018U01	50-1/2	37	25	9	45-7/8	157
24	6	HX-3534N024J03	HX-3534N024K02	HX-3534N024U01	81-1/2	68	25	24	76-7/8	214
36	9		HX-3534N036K03	HX-3534N036U01	81-1/2	68	25	24	76-7/8	225
8" -150 LB. FLANGE CONSTRUCTION, INCOLOY ELEMENTS, 20 W/IN²										
45	18		HX-3535N045K03	HX-3535N045U02	66-1/8	47-3/8	43-13/16	8-3/4	60-1/4	361
54	18		HX-3535N054K03	HX-3535N054U02	69-3/8	50-1/2	47	8-3/4	63-1/2	373
72	18		HX-3535N072K06	HX-3535N072U02	86-3/8	67-1/2	64	8-3/4	80-1/2	443
96	24		HX-3535N096K08	HX-3535N096U04	86-3/8	67-1/2	64	8-3/4	80-1/2	466
10" -150 LB. FLANGE CONSTRUCTION, INCOLOY ELEMENTS, 20 W/IN²										
80	30		HX-3536N080K05	HX-3536N080U05	77	52	48-1/2	10-3/4	71-5/8	607
90	30		HX-3536N090K05	HX-3536N090U05	81	56	52-1/2	10-3/4	75-5/8	631
100	30		HX-3536N100K10	HX-3536N100U05	87	62	58-1/2	10-3/4	81-5/8	666
120	30		HX-3536N120K10	HX-3536N120U05	97	72	68-1/2	10-3/4	91-5/8	724
140	30		HX-3536N140K10	HX-3536N140U05	105	80	76-1/2	10-3/4	99-5/8	772
12" -150 LB. FLANGE CONSTRUCTION, INCOLOY ELEMENTS, 50 W/IN²										
125	45			HX-3537N125U05	74	50	—	—	69-9/16	813
150	45			HX-3537N150U05	84	60	—	—	78-9/16	884
175	45			HX-3537N175U05	94	70	—	—	88-9/16	957
200	42			HX-3537N200U07	104	80	—	—	98-9/16	1016
16" -150 LB. FLANGE CONSTRUCTION, INCOLOY ELEMENTS, 50 W/IN²										
250	72			HX-3538N250U08	83-1/2	58	—	—	77-7/8	1110
300	72			HX-3538N300U08	93-1/2	68	—	—	87-7/8	1284
325	72			HX-3538N325U12	101-1/2	76	—	—	95-7/8	1398

* Indicates factory wired, built-on load carrying thermostat. All other built-on thermostats are pilot duty only. Last two digits of catalog number indicate number of heater circuits.

** If any special features are added to a standard heater, the part number will change to a HX-350-Series number. This part number is assigned after an order is placed.



Circulation Heaters

Water Heater Listings

The Series HX-355 (50 W/In²) Heatrex circulation heaters are designed for heating water. These high quality Water Heaters include the following standard features:

- Copper sheathed .475" diameter heating elements
- Insulated steel vessel with a galvanized jacket
- NEMA Type 1 terminal enclosure
- Built-on thermostat, 60-250° F range
- Choice of mounting brackets or mounting pads
- Flange heaters have Class 150 steel flanges which meet ANSI B16.5 standards
- Rated 160 psi at 250° F

Pad Mounting

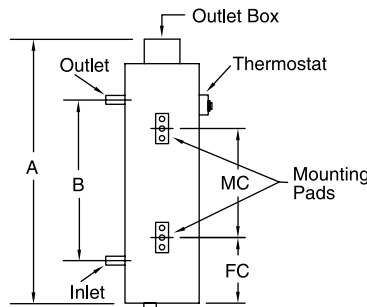

Bracket Mounting

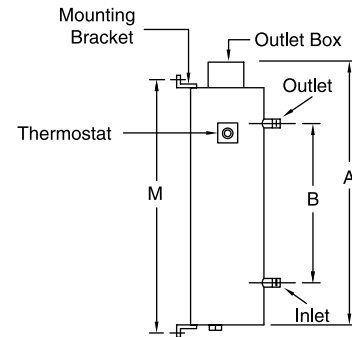

Reference Dimensional Drawings on page 8. Specify Mounting Configuration per page 9.

KW	Number Of Elements	Catalog Number**			Dimensions (Inches)					Weight (Lbs.)
		240V/1 Phase	240V/3 Phase	480V/3 Phase	A	B	MC	FC	M	
2-1/2" PIPE THREAD CONSTRUCTION, INCOLOY ELEMENTS, 12 W/IN²										
3	3	HX-3552N003J01*	HX-3552N003K01*		21-1/4	9-3/8	—	—	18-1/2	30
4.5	3	HX-3552N005J01*	HX-3552N005K01*	HX-3552N005U01	21-1/4	9-3/8	—	—	18-1/2	30
6	3	HX-3552N006J01*	HX-3552N006K01*	HX-3552N006U01	34-3/8	22-1/2	16-1/2	5-5/8	31-5/8	40
7.5	3	HX-3552N008J01*	HX-3552N008K01*	HX-3552N008U01	34-3/8	22-1/2	16-1/2	5-5/8	31-5/8	41
9	3	HX-3552N009J01*	HX-3552N009K01*	HX-3552N009U01	34-3/8	22-1/2	16-1/2	5-5/8	31-5/8	41
3" -150 LB. FLANGE CONSTRUCTION, INCOLOY ELEMENTS, 12 W/IN²										
6	3	HX-3553N006J01*	HX-3553N006K01*	HX-3553N006U01	34-1/4	22-1/2	16-1/2	4-1/8	30-1/4	65
9	3	HX-3553N009J01*	HX-3553N009K01*	HX-3553N009U01	34-1/4	22-1/2	16-1/2	4-1/8	30-1/4	66
12	3	HX-3553N012J03	HX-3553N012K01*	HX-3553N012U01	46-1/4	34-1/2	26-1/2	4-1/8	42-1/4	81
15	3	HX-3553N015J03	HX-3553N015K01	HX-3553N015U01	56-3/4	45	39	4-1/8	52-3/4	91
18	3	HX-3553N018J03	HX-3553N018K01	HX-3553N018U01	56-3/4	45	39	4-1/8	52-3/4	93
5" -150 LB. FLANGE CONSTRUCTION, INCOLOY ELEMENTS, 12 W/IN²										
24	6	HX-3554N024J03	HX-3554N024K02	HX-3554N024U01	43-1/2	30	25	4-3/4	38-7/8	135
30	6		HX-3554N030K02	HX-3554N030U01	50-1/2	37	25	9	45-7/8	150
45	9		HX-3554N045K03	HX-3554N045U03	50-1/2	37	25	9	45-7/8	157
63	9			HX-3554N063U03	62	48-1/2	25	14	57-3/8	181
8" -150 LB. FLANGE CONSTRUCTION, INCOLOY ELEMENTS, 12 W/IN²										
72	18		HX-3555N072K06	HX-3555N072U02	53-3/8	34-1/2	31	8-3/4	47-1/2	302
96	24		HX-3555N096K08	HX-3555N096U04	53-3/8	34-1/2	31	8-3/4	47-1/2	312
126	18			HX-3555N126U06	66-1/8	47-3/8	43-13/16	8-3/4	60-1/4	361
144	18			HX-3555N144U06	75-5/8	56-7/8	53-5/16	8-3/4	69-3/4	396
180	18			HX-3555N180U06	86-3/8	67-1/2	64	8-3/4	80-1/2	443
240	24			HX-3555N240U08	86-3/8	67-1/2	64	8-3/4	80-1/2	466
12" -150 LB. FLANGE CONSTRUCTION, INCOLOY ELEMENTS, 12 W/IN²										
250	42			HX-3557N250U07	64	40	—	—	58-9/16	748
300	48			HX-3557N300U08	74	50	—	—	68-9/16	819
350	48			HX-3557N350U16	84	60	—	—	78-9/16	889
400	48			HX-3557N400U16	84	60	—	—	78-9/16	906
450	48			HX-3557N450U16	84	60	—	—	78-9/16	924
500	48			HX-3557N500U16	94	70	—	—	88-9/16	942
16" -150 LB. FLANGE CONSTRUCTION, INCOLOY ELEMENTS, 20 W/IN²										
500	72			HX-3558N500U24	73-1/2	48	—	—	67-7/8	1110
600	72			HX-3558N600U24	83-1/2	58	—	—	77-7/8	1210
700	72			HX-3558N700U24	93-1/2	68	—	—	87-7/8	1284
800	72			HX-3558N800U24	101-1/2	76	—	—	95-7/8	1399

* Indicates factory wired, built-on load carrying thermostat. All other built-on thermostats are pilot duty only. Last two digits of catalog number indicate number of heater circuits.

** If any special features are added to a standard heater, the part number will change to a 350-Series number. This part number is assigned after an order is placed.

Mini-Booster Compact Water Heaters

These compact, light-weight, easy to install heaters can be used for many commercial or light industrial water heating applications. The high quality Mini-Booster Water Heater includes the following standard features:

- 1-1/4" pipe thread immersion heater with integral load carrying 60° to 180° F thermostat
- Insulated galvanized steel pipe vessel with painted steel jacket
- Two .312" diameter copper elements rated at 80 W/In²
- NEMA Type 1 terminal enclosure
- No mounting brackets required
- Dual voltage design allows for operation with 120V or 240V power supply

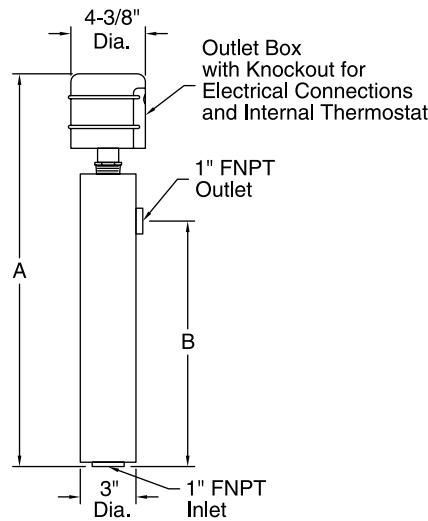

KW	Catalog Number** 120V/1 Phase or 240V/1 Phase	Dimensions (Inches)		Weight (Lbs.)
		A	B	
1.5	HX-3591S01.5X01	19-7/8	12-3/8	10
2	HX-3591S02.0X01	19-7/8	12-3/8	10
2.5	HX-3591S02.5X01	23-7/8	16-3/8	12
3	HX-3591S03.0X01	23-7/8	16-3/8	12

** If any special features are added to a standard heater, the part number will change to a 350-Series number. This part number is assigned after an order is placed.

How to Order

Standard Heater Construction

Specify:

- Catalog number
- Mounting configuration

Custom Designs

Required Application Information:

- Fluid or gas to be heated
- Required temperature rise (ΔT)°F through the heater
- Maximum outlet temperature
- Flow rates (minimum and maximum)
- Maximum design pressure
- Maximum allowable pressure drop through the heater
- Heater environment (hazardous, corrosive, weatherproof, etc.)
- Temperature control requirements

Specify:*

- KW
- Voltage and phase
- Nominal heater/vessel configuration (2-1/2" pipe plug; 3", 5", 8", 10" or larger flange size)
- Maximum vessel design pressure (standard design based on 160 psi rating at 250° F, with Class 150 flange standard)
- ASME code stamp required (none or VIII)
- Vessel material (steel, stainless, other)
- Element sheath material (Incoloy, steel, copper, stainless, other)
- Element watt density (W/In²)
- Inlet/outlet connection (NPT or flanged)
- Mounting configuration
- Method of temperature/power control
- Special features

*Heatrex can help determine custom design specifications or may advise a better choice to reduce cost and delivery time.



Control Panels

Heatrex can provide a control system for any electric process heating application. Standard and custom sized enclosures, along with custom designed control operation, give Heatrex the flexibility to supply a wide range of remote, built-on or skid-mounted control panels to complete the heater control system. Our experienced engineering staff can design control systems ranging from ON/OFF logic to fully proportional SCR, multiple channel and ramp/soak control with computer interface capability.

Heatrex offers two standard control panel designs: Fully proportional SCR control and ON/OFF contactor control. All components are factory mounted and wired in compliance with the National Electric Code.

These charts provide a sample of standard control panel designs. Custom control panels, designed specifically for your application, are available.

A Vernier control panel can also be supplied. Vernier control utilizes contactors, one SCR controller, and a microprocessor-based sequencer. The sequencer controls the staging of the contactors and the SCR controller. The SCR controller serves to fill in the gaps between the step-controlled stages. Vernier control is not quite as accurate as full SCR control, but more accurate than contactor (step) control.

Contactor Control Panels

This contactor-based system with ON/OFF process temperature control is recommended for less demanding applications. Systems with two or more heating stages utilize an electronic sequencer (step controller), driven by a proportional output temperature controller to minimize the amount of load cycling while providing good outlet temperature control.

Standard Features:

- Microprocessor-based sequencer (for panels with two or more heating stages)
- Proportional indicating temperature controller (adjustable process temperature with thermocouple input)
- NEMA 12 painted steel enclosure, wall mount unless otherwise noted
- Overtemperature controller (adjustable temperature limit with thermocouple input)
- Door interlock disconnect switch
- Manual reset pushbutton with built-in pilot light (red) for visual "OVERTEMPERATURE" alarm
- Selector switch – ON/OFF with built-in pilot light (green) for "POWER ON" indication
- Control transformer
- Disconnecting magnetic contactors
- Circuit fusing

Amps	Number Of Circuits	Amps Per Circuit	Maximum KW		Approximate Dimensions (Inches)			Estimated Weight (Lbs.)
			240V/3PH	480V/3PH	Height	Width	Depth	
48	1	48	19	39	24	24	8	85
96	2	48	39	79	30	24	8	105
144	3	48	59	119	36	30	8	160
192	4	48	79	159	42	30	8	175
240	5	48	99	199	48	36	8	260
288	6	48	119	239	48	36	8	265
336	7	48	139	279	60	36	8	320
384	8	48	159	319	60	36	8	330
432*	9	48	179	359	60	48	12	585
480*	10	48	199	399	60	48	12	600
528*	11	48	219	438	60	60	12	680
576*	12	48	239	478	60	60	12	685
624*	13	48	259	518	72	60	12	800
672*	14	48	279	558	72	60	12	805
720*	15	48	299	598	72	60	12	815
768*	16	48	319	638	72	72	12	930
816*	17	48	339	678	72	72	12	945
864*	18	48	359	718	72	72	12	950
912*	19	48	379	758	72	72	12	960
960*	20	48	399	798	72	72	12	965

*These panels have double doors and 12" high floor stands.

SCR Control Panels

A fully proportional SCR system with PID temperature control is recommended for industrial heating applications which must accommodate material flow changes and provide the highest degree of accuracy for outlet temperature control.

Standard Features:

- PID self-tuning temperature controller (adjustable process temperature, with thermocouple input)
- Three-phase, zero cross-fired, SCR power controllers
- NEMA 12 painted steel enclosure, wall mount unless otherwise noted
- Overtemperature controller (adjustable temperature limit

with thermocouple input)

- Door interlock disconnect switch
- Manual reset pushbutton with built-in pilot light (red) for visual "OVERTEMPERATURE" alarm
- Selector switch – ON/OFF with built-in pilot light (green) for "POWER ON" indication
- Control transformer
- Safety contactors
- Circuit fusing
- Ventilating fan and filter when required

Amps	Number Of Circuits	Amps Per Circuit	Maximum KW		Approximate Dimensions (Inches)			Estimated Weight (Lbs.)
			240V/3PH	480V/3PH	Height	Width	Depth	
48	1	48	19	39	24	24**	8	95
70	1	70	29	58	30	24**	8	115
96	2	48	39	79	30	24**	8	125
140	2	70	58	116	42	30**	8	205
144	3	48	59	119	36	30**	8	195
210	3	70	87	174	48	36**	8	310
192	4	48	79	159	42	30**	8	225
280	4	70	116	232	60	36**	8	385
240	5	48	99	199	48	36**	8	320
350	5	70	145	290	60	36**	8	415
SCR panels with internally mounted heat sinks, fan and filter								
295	6	48	119	239	60	36	16	405
425*	9	47	175	351	60	48	16	660
590*	12	48	239	478	60	60	16	750
850*	18	47	351	703	72	72	16	1090

*These panels have double doors and 12" high floor stands.

**Additional 9" clearance required for externally mounted heat sinks which may be mounted on one or both sides of the enclosure for proper convection cooling.

SCR Power Controllers modulate the entire heater load directly, varying the heater output from 0 to 100% of the total heater KW. Working on a four second time base, the heater will be energized only for the number of AC cycles necessary to produce the exact amount of heat required. The resulting precision control and rapid response make SCR the choice for many heating applications. For example, multi-stage discharge temperature control of a heater can produce unacceptable temperature swings, resulting in inefficient energy use. The

same heater controlled by the SCR and process temperature controller will produce stable, even heat for maximum performance and efficiency.

The SCR's power switching devices are mounted on a large finned heat sink which extends outside the heater terminal box or control panel. The conservative SCR rating (no more than 75% of the manufacturer's rating) and this generous heat sink insure against overheating and SCR failure.

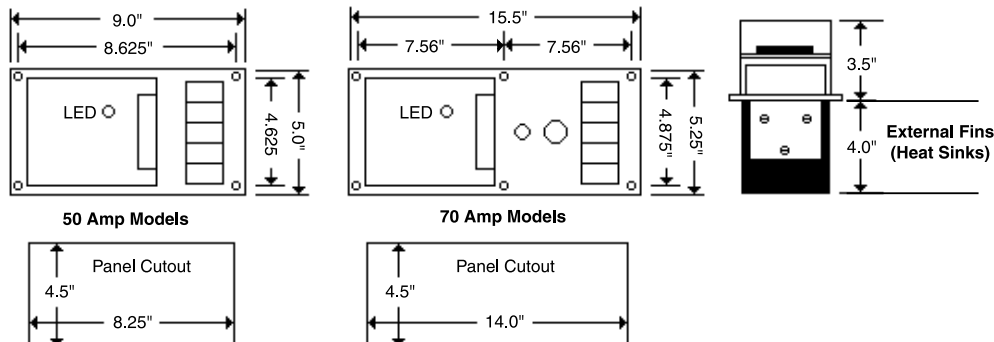

Control Panels

Special Features

Control Relays – These relays are activated by safety devices, such as a flow switch or remote shutoff.

Remote Interlock Terminals – Control circuit terminals are supplied so the heater can be de-energized from remote contacts.

Indicator Lights – Additional indicator lights may be specified for visual indication of system status, such as “LOW TEMPERATURE”.

Audible Alarm Package – This package includes a horn, pilot light, latching relay and a push button for silencing the horn.

Low Liquid Cutoff – The relay is mounted and wired with sensing probe shipped loose for field installation.

Skid Mounted Panel – The control panel and heater are mounted together and prewired on a rugged steel skid. This provides a modular system that minimizes installation time and expense.

Special Controllers – The customer may specify the use of special process or overtemperature controllers for a different temperature range, sensor input, control mode, etc.

Panel Heater – A heater and thermostat are provided to prevent condensation and maintain minimum ambient temperature for electrical components.

Wire Markers – Identification markers are attached to both ends of all control and power wires.

Tagging of Internal Parts – Permanent tags are attached to the sub-panel near internal parts and marked with component titles as noted on the wiring diagram.

UL Listing – Available on most designs.

Explosion-Resistant Panel – A cast aluminum enclosure is rated for Class I, Groups C & D and Class II, Groups E, F & G (NEMA 7, 9).

Purged Panels – Type Z for Class I, Division 2 areas

Type X for Class I, Division 1 areas

Special Coatings – Epoxy or other paints may be specified.

12” High Floor Stand – This construction allows the control panel to be floor mounted.

NEMA 4 Panel Enclosure – Features a gasketed weatherproof construction.

NEMA 4 Instrument Window – This feature allows for access to a control instrument without opening the control panel door.

Stainless Steel Panel Enclosure (NEMA 4X) – This construction provides extra corrosion resistance for harsh environments.

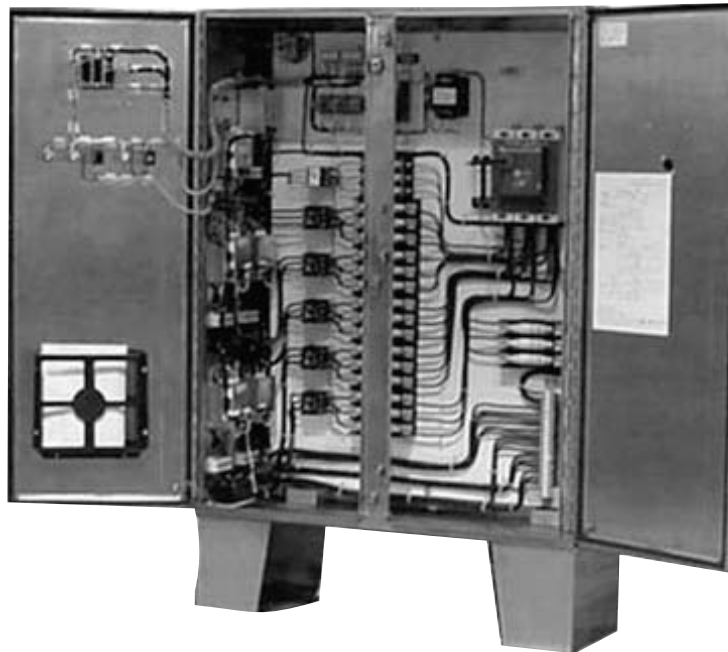

Tank Heaters

Electric Tank Heaters are used to raise or maintain temperatures from -300° F to 1000° F for a wide variety of liquids and gases found in storage tanks and process vessels. These heaters are designed with low watt density open coil heating elements for uniform heating of temperature sensitive material.

Materials Heated:

- Adhesives
- Asphalt
- Caustic Soda
- Chocolate
- Dyestuffs
- Emulsions
- Fish/Animal Oils
- Fuel Oils
- Inorganic Heavy Chemicals
- Margarine
- Molasses
- Organic Chemicals
- Paint
- Varnish
- Paraffin
- Pitch
- Resins
- Shortening
- Sulphur
- Syrups
- Synthetic Fibers
- Tar
- Vegetable Oils

Open Coil Heating Elements

Open Coil Heating Elements are custom designed and manufactured to meet precise OEM or end user applications.

Advantages

- Low watt density (1-15 W/In²) design prevents carbonization or decomposition of temperature sensitive materials.
- Flexible element design allows installation in tanks with as little as four feet clearance to obstructions.
- Heating elements may be removed for inspection or replacement without draining the tank.

Design and Construction

- Designs to fit in 2" and 3" pipe or nested assembly to fit larger pipe sizes.
- Available in lengths up to 40 feet.
- Open coil elements can be installed in Heatrex or customer supplied pipe. Typical pipe materials include steel, stainless steel, nickel, Monel and Inconel.
- Voltages up to 600V; single-phase or three-phase.
- Rugged, industrial grade construction.
- Conservative design insures long life.



Storage Tank Heaters

- Adaptor box and flanged designs available. Both permit easy installation in the curved wall of a vertical tank or dished head of a horizontal tank.
- Steel, stainless, nickel, graphite and other pipe materials are available to suit the material being heated.
- Automatic temperature control. Optional two-stage thermostat reduces amperage draw and maintains close temperature control.
- Heavy pipe wall provides up to .125" corrosion allowance.



Railroad Tank Car Heaters

- For restoring heat lost in transit.
- To liquify material for draining or pumping out of tank cars.
- Special element design resists shock and vibration.
- Tank car or trackside controls available.



Limited Warranty

Heatrex products are warranted against defects in workmanship, material, design, labeling and packaging. No other warranty, expressed or implied, written or oral, applies. No person other than an officer or the general manager of Heatrex is authorized to give any other warranty or assume any liability.

Warranty Period: This warranty is effective for eighteen months from the date of shipment of the product from Heatrex's factory, or for twelve months from the date the product is first placed in service, whichever period lapses first.

Conditions of Warranty: Heatrex products must be installed, operated and maintained in accordance with Heatrex's instructions. Heatrex is not liable for damage or unsatisfactory performance of the product resulting from accident, negligence, alteration, unauthorized repair, improper application or installation of the product, improper specifications or corrosion. Heatrex IS NOT LIABLE FOR ANY INCIDENTAL OR CONSEQUENTIAL DAMAGES. Claims against carriers for damage in transit must be filed by the purchaser with the carrier.

Remedy: The part or product in question should be returned, freight prepaid, to:

Heatrex

Attention: Return Goods Manager

If after receipt of the product and the claim, Heatrex finds to its reasonable satisfaction that the product is defective in workmanship, material, design, labeling or packaging, the product will be repaired or replaced or the purchase price refunded at Heatrex's option. There will be no charge to the purchaser for parts or labor. Removal and reinstallation of the product, and shipment of the product to Heatrex for repair or inspection shall be at the purchaser's risk and expense.

THE REPAIR, REPLACEMENT OR REFUND PROVIDED FOR IN THIS LIMITED WARRANTY IS THE EXCLUSIVE REMEDY OF THE PURCHASER. THIS WARRANTY IS EXPRESSLY IN LIEU OF ANY OTHER WARRANTIES, EXPRESSED OR IMPLIED, INCLUDING ANY WARRANTY OF MERCHANTABILITY OR FITNESS FOR A PARTICULAR PURPOSE. THERE ARE NO WARRANTIES WHICH EXTEND BEYOND THE TERMS OF THIS LIMITED WARRANTY.



www.heatrex.com

FOR YOUR NEAREST HEATREX REPRESENTATIVE CALL:

814-724-1800 • 800-394-6589 • 814-333-6580 [fax]