

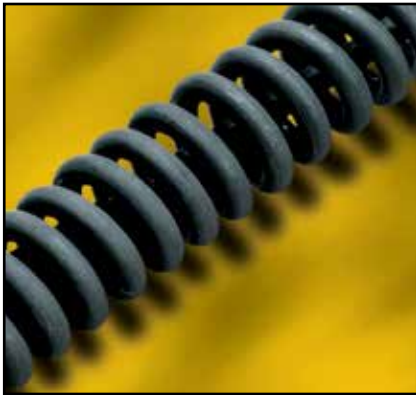

ELECTRIC HEAT FOR INDUSTRY



ELEMENT CATALOG

Table Of Contents

- Construction1-2
- Quality Control 2
- Physical & Electrical Specifications.....3-4
- Application 5
- Watt Density & Sheath Selection 6-18
- Terminals, Insulators & Seals 19-23
- Bending 24-30
- Mounting Accessories 31-32
- Limited Warranty Back Cover



Introduction

Heatrex designs and manufactures commercial and industrial electric heating and control systems that set the industry standard for excellence. The company's heating solutions reflect more than 55 years of innovation, product quality and efficient service.

Our product offering ranges from the tubular heating elements described in this catalog to the most sophisticated, custom designed systems. Heatrex's attention to detail and rigorous testing give worldwide customers premium products that they receive quickly and at a fair market price.

Construction

One-Pass Construction

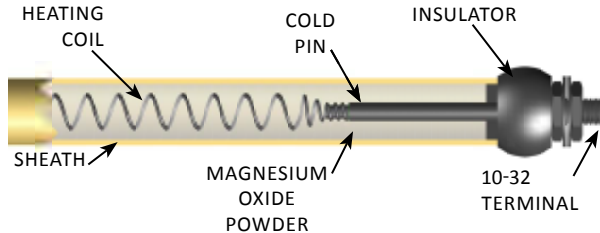

The cutaway view of a typical Heatrex tubular element shows its basic construction. A coil of high grade-resistance wire (nickel, chromium) is precisely centered in a heavy gauge metal tube while the tube is filled with granular magnesium oxide powder. Cold pins are welded to the resistance coil at each end to provide an unheated length near the terminals and to secure the coil in the magnesium oxide. Through rolling, the diameter of this assembly is reduced and the magnesium oxide compacted, insuring rapid heat transfer from the coil to the sheath, as well as high dielectric strength.

After compaction, the element is processed in one of three ways:

1. **Straight length elements** are sealed and appropriate terminals applied.
2. **Formed elements are annealed** and bent before they are sealed and terminated.
3. **Finned elements** are wound with a helical fin before processing as described in #1 and #2 above.

Two-Pass Construction

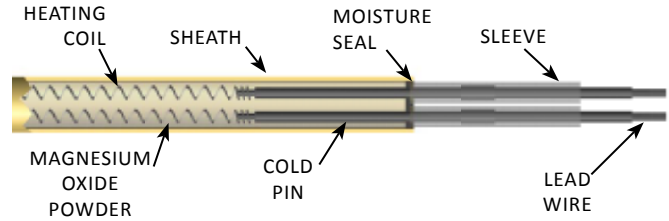

For applications requiring both terminations at the same end, two-pass construction may be used. Two-pass elements, as shown in the cutaway view, have a U-bent coil inside the sheath and two leads or terminals at one end. The opposite end is sealed by welding or silver soldering. These elements are available in straight lengths, either finned or unfinned. They can be permanently mounted with a variety of factory-furnished mounting methods see page 31 and 32. By contrast, one-pass elements in straight lengths must have a flexible electrical connection at one end to allow for thermal expansion.

Finned Construction

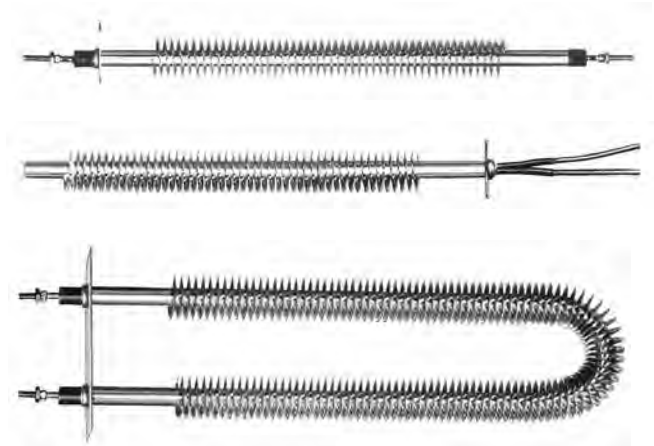

A corrugated metal fin is helically wound on a tubular element to improve heat transfer in air applications. Depending on the sheath and fin material selected, the fins are either permanently attached, mechanically or via furnace brazing. The entire assembly then goes through a computer controlled atmosphere furnace. This process prepares the element to be bent into a variety of configurations. Standard fin density is five fins per inch, while eight fins per inch can be furnished when specified for lower sheath temperatures.

Construction/Quality Control

Construction Techniques

Heatrex construction techniques are designed to insure high quality and long life.

- **Rolling** – All standard diameter elements listed in this catalog are compacted through multi-stage rolls. This process insures uniform compaction of the magnesium oxide, a truly round cross section and a consistent diameter. This is critical if the element is being inserted into a machined hole.
- **Terminal Construction** – A threaded stainless steel terminal is welded onto the cold pin for the standard construction. Stainless steel nuts and washers are furnished for field wiring. The terminal must be prevented from rotating when connecting field wiring.
- **Terminal insulator and seals** — Element ends are normally sealed against moisture, which can rapidly deteriorate the insulating properties of magnesium oxide. The terminal

insulator and seal must be suitable for the temperature, voltage and atmospheric conditions of the application. Heatrex offers a wide variety of terminals, insulators and seals to meet virtually any combination of field conditions (see pages 19 thru 23).

- **Recompaction** – In the process of bending, density is reduced in the compacted magnesium oxide. These reductions, in turn, can lead to overheating and coil failure, especially at high temperatures or high watt densities. To prevent such failures, we recompress bends to improve density in the magnesium oxide when necessary.

Quality Control

From raw materials through the finished product, Heatrex maintains the highest standards in the industry through a series of Quality Control/Assurance checks.

- **Magnesium Oxide** – Heatrex uses the highest grade MgO available for electric heating elements under various applications. Each batch is checked against two ASTM Standards: ASTM D3347 determines tap density to assure a high insulation density. ASTM D2755 is used for sieve analysis. Samples are sifted through ten progressively finer sieves to assure a normal distribution and controlled concentration of grains. As a result, Heatrex elements have extremely high MgO density.
- **Certification to Special Standards** – Elements can be certified to Military Standards such as MIL-H-22577 Rev C and MIL-PRF-22594 Rev C, and special customer specifications regarding tolerances, hydrostatic testing, etc. Please consult the factory for details.

UL and CSA Recognition

Most of the elements described in this catalog are Recognized by the Underwriters Laboratories under UL Standard 1030. Our File No. is E78533. In addition, elements for refrigeration defrost are Recognized under File No. SA3254. Such recognition makes it simpler for manufacturers to incorporate Heatrex elements into equipment that is UL or Third Party Listed. Tubular and finned tubular elements are also CSA approved under contract No. 151727, Class 2871-02, 2871-82. Elements may also be supplied with CE markings required for the European Communities upon request. Please consult the factory for details.

Physical & Electrical Specifications

Table I
Tubular Element Diameters

Description	Tubular Element Diameters											
	One-Pass Coil									Two-Pass Coil		
	0.200	0.250	0.260	0.315	0.375	0.430	0.475	0.490	0.625	.235 x 1.00 Oval	0.430	0.475
Available Sheath Materials(1) (Max Sheath Temp)												
Copper (350°F)	—	X	X	X	—	X	X	—	—	—	X	X
Steel (750°F)	—	—	—	X	—	X	X	X	—	—	X	X
304 SS (1400°F)	—	X	X	X	X	X	X	X	—	—	X	X
316 SS (1400°F)	—	—	—	X	—	X	X	X	—	—	X	X
Incoloy 800 (1700°F)	—	X	X	X	X	X	X	X	—	X	X	X
Inconel 600 (1800°F)	—	—	—	—	—	X	X	X	X	—	X	X
Monel (900°F)	—	X	X	X	—	X	X	X	—	—	X	X
Copper Plated Steel (750°F)	—	X	X	X	—	X	—	—	—	—	X	—
321 SS (1400°F)	—	X	X	X	X	X	X	X	X	—	X	X
Titanium (750°F)	—	—	—	X	—	X	—	—	—	—	X	—
Copper-Nickel (350°F)	—	X	X	—	—	—	X	—	—	—	—	X
Incoloy 840 (1700°F)	X	X	X	X	X	X	X	X	X	—	X	X
Sheath Diameters												
Minimum	0.195	0.245	0.255	0.308	0.370	0.425	0.470	0.485	0.620	.230 x 0.095	0.425	0.470
Maximum	0.205	0.255	0.265	0.320	0.380	0.435	0.482	0.495	0.630	.240 x 1.005	0.435	0.482
Standard Wall Thickness(2)	0.018	0.018 0.025 0.028	0.018 0.025 0.028	0.018 0.025 0.028	0.018 0.030	0.028 0.035	0.035	0.035	0.035 0.049	0.032	0.028	0.035
Sheath Lengths												
Minimum	6	6	6	6	6	6	6	6	6	13	6	6
Maximum (5)	88	359	338	333	321	319	333	317	319	145	79	170
Sheath length tolerances (4)	1 % of overall sheath length with a minimum of 1/8"											
Heated length tolerances (4)	1 % of overall sheath length with a minimum of 1/2"											
Cold Ends												
Minimum	1.5	1.5	1.5	1.5	1.5	1.5	1.5	1.5	1.5	1.5	1.5	1.5
Maximum	10	32	32	32	32	45	45	45	45	10	10	16
Maximum Current Draw	15	30	30	40	40	40	55	55	60	15	15	30
Maximum Voltage	240	300	300	480	480	600	600	600	600	240	240	300
Wattage Tolerance	+5% / -10%											
Ohms/Inch												
Minimum	.096	.032	.035	.020	.020	.015	.015	.015	.014	.300	.200	.070
Maximum	21	28	30	35	35	33	35	37	35	30	35	35

(1) Table indicates sheath materials commonly used. Consult factory for availability of material required.

(2) When multiple wall thicknesses are listed, confirm with factory for standard wall thickness.

(3) Unless noted otherwise, all dimensions are in inches.

(4) Consult factory for special tolerances needed.

(5) Consult factory for length outside range, standards shown.

Physical & Electrical Specifications

Table II
Finned Tubular Element Diameters

Description	Finned Tubular Element Diameters									
	One-Pass Coil								Two-Pass Coil	
	0.250	0.260	0.315	0.375	0.430	0.475	0.490	0.625	0.430	0.475
Sheath/Fin Materials (1) (Max Sheath Temp)	Available (Fin Height)									
Copper Plated Steel/Steel (750°F)	X(.25)	X(.25)	X(.25)	N/A	N/A	N/A	N/A	N/A	N/A	N/A
304 SS/304 SS (1400°F)	X(.25)	X(.25)	X(.25)	X(.32)	X(.32)	X(.32)	X(.32)	N/A	X(.32)	X(.32)
316 SS/304 SS (1400°F)	X(.25)	X(.25)	X(.25)	X(.32)	X(.32)	X(.32)	X(.32)	N/A	X(.32)	X(.32)
Monel/Monel (900°F)	X(.32)	X(.32)	X(.32)	X(.32)	X(.32)	X(.32)	X(.32)	N/A	X(.32)	X(.32)
Steel/Copper Plated Steel (750°F)	N/A	N/A	N/A	X(.32)	X(.32)	X(.32)	X(.32)	N/A	X(.32)	X(.32)
321 SS/304 SS (1400°F)	X(.25)	X(.25)	X(.25)	X(.32)	X(.32)	X(.32)	X(.32)	X(.32)	X(.32)	X(.32)
Sheath Diameters (4)										
Minimum	0.245	0.255	0.308	0.370	0.425	0.470	0.485	0.620	0.425	0.470
Maximum	0.255	0.265	0.320	0.380	0.435	0.482	0.495	0.630	0.435	0.482
Standard Wall Thickness (2)	0.018 0.025 0.028	0.018 0.025 0.028	0.018 0.025 0.028	0.018 0.030	0.028 0.035	0.035	0.035	0.035 0.049	0.028 0.035	0.035
Fin Thickness	0.015	0.015	0.015	0.015	0.015	0.015	0.015	0.015	0.015	0.015
Overall Fin Diameter										
Minimum	Sheath Diameter + 2* Fin Height - .032									
Maximum	Sheath Diameter + 2* Fin Height + .032									
Sheath Lengths										
Minimum	8	8	8	8	6	6	6	8	6	6
Maximum	133.5	133.5	133.5	133.5	133.5	249	249	133.5	79	170
Sheath length tolerances (4)	1% of overall sheath length with a minimum of 1/8"									
Heated length tolerances (4)	1% of overall sheath length with a minimum of 1/2"									
Cold Ends										
Minimum	1.5	1.5	1.5	1.5	1.5	1.5	1.5	1.5	1.5	1.5
Maximum	32	32	32	32	45	45	45	45	10	16
Maximum Current Draw	30	30	40	40	40	55	55	60	15	30
Maximum Voltage	300	300	480	480	600	600	600	600	240	300
Wattage Tolerance (4)	+5%/-10%									
Ohms/Inch										
Minimum	.032	.035	.020	.020	.015	.015	.015	0.14	.200	.070
Maximum	28	30	35	33	35	35	37	35	35	35

- (1) Table indicates sheath materials commonly used. Consult factory for availability of material required.
- (2) When multiple wall thicknesses are listed, confirm with factory for standard wall thickness.
- (3) Unless noted otherwise, all dimensions are in inches.
- (4) Consult factory for special tolerances needed.
- (5) Consult factory for length outside range, standards shown.

Tubular elements may be applied in a variety of ways as illustrated below.

Clamped — Elements clamped onto a surface establish essentially line contact. Thus this method should be used only at relatively low temperatures. Where possible, it is preferable to insert elements in machined openings as described below. When installing, follow these rules:

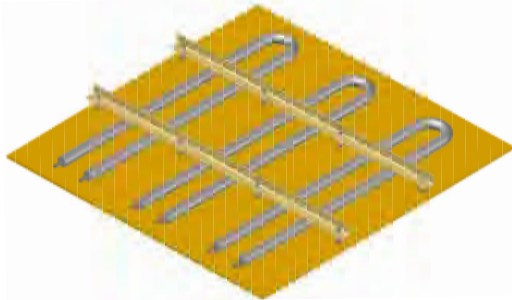

1. Clamping must be accomplished in such a way that the element is free to expand and contract as it heats up and cools down. It is generally best to clamp tightly, then back off the clamping nuts or bolts one-half turn to allow for expansion.
2. Elements should be spaced on approximately 2" centers.
3. If insulation is used, provide an air space between the elements and the insulation, as it should never be in direct contact with the element sheath.

Inserted into Drilled Holes — Elements may be slipped into drilled holes in metal platens or dies. However, this method is generally restricted to relatively short lengths because of the problems of drilling a straight, uniform hole in longer lengths. For longer lengths, it is often more practical to machine semi-cylindrical grooves in two matching dies or platens and sandwich the element between the two. When installing, follow these rules:

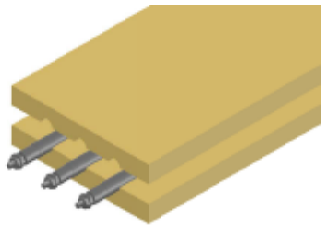

1. Holes should be drilled .003" to .005" oversized.
2. Spraying the element with a silicone or graphite lubricant before insertion will facilitate installation and removal.
3. See above for spacing and insulating instructions.

Cast In — Elements may be cast into a variety of metals for applications requiring uniform heat distribution. If the casting is to be machined, it is critical to hold the element precisely in position as the metal is being cast, to avoid machining into the sheath of the element heater.

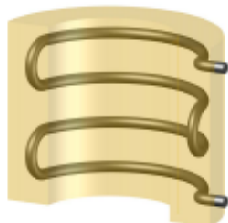

Immersion — For immersion applications, elements are normally furnished with threaded fittings as listed in Heatrex's Immersion Catalog, or bent in such a way that the terminals protrude over the side of the vessel. When installing, following these rules:

1. The element heated section must be fully immersed.
2. Choose the proper sheath material and watt density for the liquid from Table III, Page 8-17.

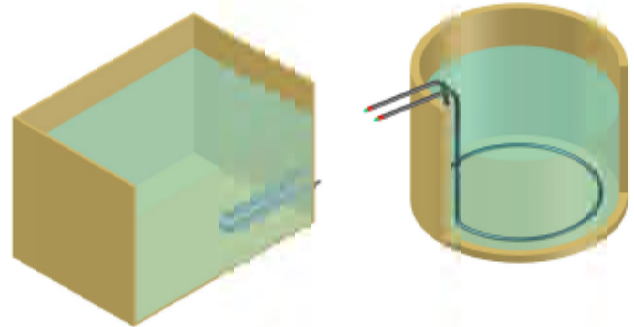

Radiant Applications — Stainless steel or Incoloy sheathed elements may heat processes by radiation. A reflector is recommended to reduce waste heat and increase process efficiency. The element temperature will vary with the work temperature, the distance between the work and the element and atmospheric conditions. See Heatrex's Radiant Heater Catalog for fully assembled heaters.



Air Heating — Either finned or unfinned elements can be used in both forced and natural convection applications. Finned elements are usually preferred for heating low pressure, low temperature air and other gases, and for natural convection, since their extended surface reduces sheath operating temperatures. Unfinned elements are preferred for high temperatures (over 400°F), for compressed gases and when there are airborne particles such as lint or straw that may catch in the fins. When installing, follow these rules:

1. Elements over 24" long should be supported on two to three foot centers.
2. In forced air applications, be sure the airflow is evenly distributed. If necessary, install a pressure plate in front of the element to redistribute airflow.
3. To allow for expansion and contraction of straight elements, one end should slip freely through a rounded hole in a support bracket. Unless a two-pass element is used, the electrical connection at this end must be flexible. Elements will expand approximately 1/8" per foot of heated length.
4. See Heatrex's Process Air heating catalog for fully assembled heaters.

Watt Density & Sheath Selection

Watt Density – Watt density is one of the most critical factors affecting element life. Watt density, expressed in watts per square inch of heater surface area, determines the heater operating temperature for a given set of conditions. The sheath temperature of an electric heating element should be limited to provide a reasonable heater life and to avoid possible damage of the medium being heated. We can estimate the sheath temperature or select the appropriate watt density based on the charts and tables provided.

Watt density is calculated as follows:

Watt Density = element wattage/3.14 x element diameter (inches) x heated length (inches)

An example is:

An 8 kW flange heater has three 0.475" diameter elements with a "B" dimension of 47 inches and a 2 inch cold end. The watt density is:

$$\begin{aligned} 0.475 \times 3.14 \times (47 \text{ in.} - 2 \text{ in.}) \times 3 \text{ (\# of elements)} \times 2 \text{ (u-bend)} &= \\ 403 \text{ in}^2 & \\ 8,000 \text{ Watts} \div 403 \text{ in}^2 &= 20 \text{ W/in}^2 \end{aligned}$$

Sheath Material – Also critically important, the sheath material must be suitable for the corrosive conditions and the extreme temperatures of the application. Copper sheathed elements are typically used for low temperature applications such as heating water and some aqueous solutions. Steel is generally used with oil heating applications. Stainless steel and INCOLOY® are used when heating corrosive solutions or high-temperature gas/air. Table I and II list the maximum recommended operating temperatures for common sheath materials.

Watt Density and Sheath Material Selection – Selecting the proper watt density and the proper sheath material is critical to heater life and, if applicable, fluid integrity. If the watt density is too high, the fluid may carbonize, break down chemically, or the elements may burn out. If the watt density is too low the heater price will be high. The greatest heater life will come from the lowest watt density practical for the application.

In general, watt density is determined by three factors:

- 1) maximum outlet temperature
- 2) type of fluid heated and
- 3) fluid flow rate

Sheath material depends on the type of fluid and maximum temperature. If the sheath material selection is incorrect, it will corrode, destroying the element

Heating Air and Other Gases – Charts A through C give maximum sheath temperatures for a range of watt densities and velocities. This data is based upon air at atmospheric pressure and a 75°F inlet air temperature. For higher inlet temperatures, the sheath temperature will increase accordingly. Contaminants in the air, while normally not affecting the sheath temperature, may require a more highly corrosion-resistant sheath and/or fin material. For heating compressed air and other gases, consult the factory or your local Heatrex representative for watt density and sheath recommendations.

Watt Density & Sheath Selection

Chart A

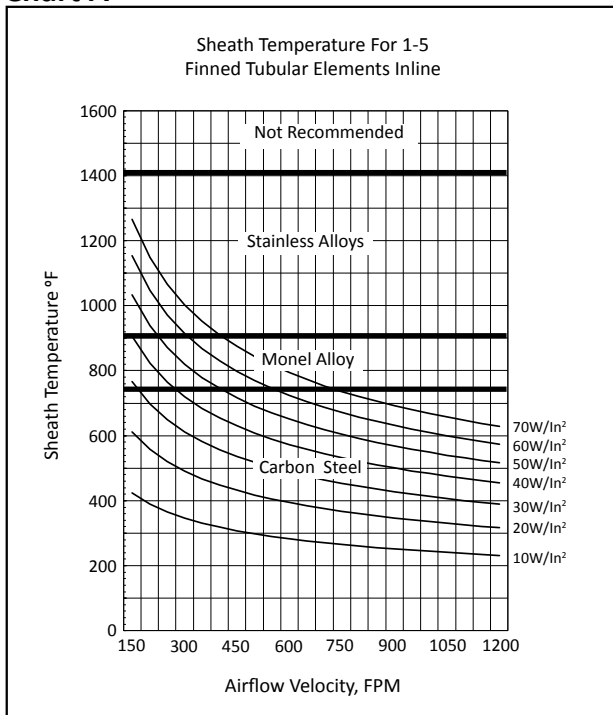

Chart B

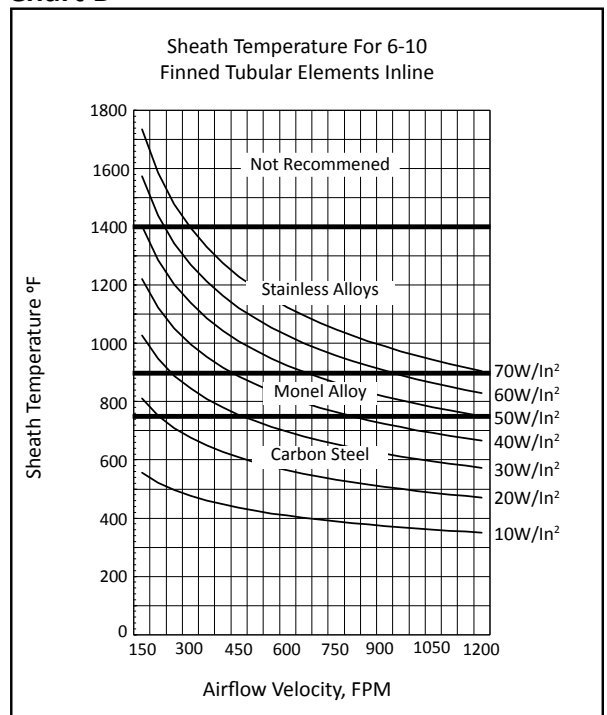
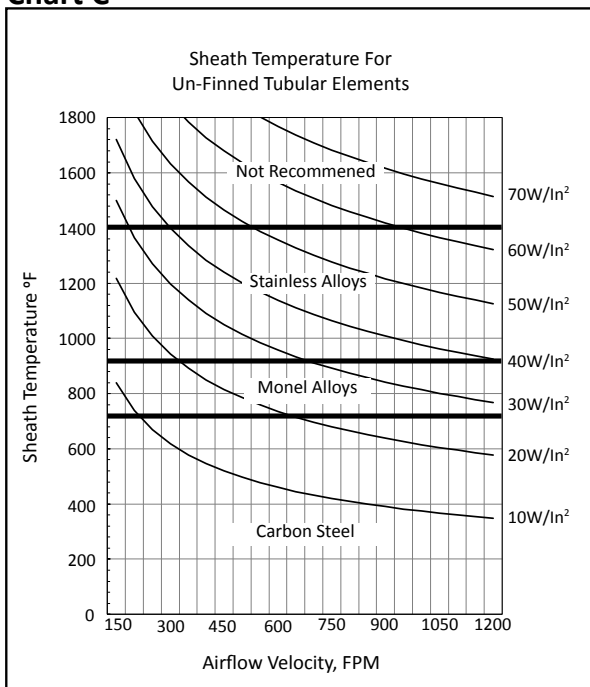

Chart C



Watt Density & Sheath Selection

Watt Density and Sheath Materials – Table III has sheath materials recommended for each fluid and temperature. Where a range of watt densities are shown, the lower end of the range represents a more conservative design.

While Table III represents our most current knowledge, many application factors are beyond our control. Thus, this table should be used only as a guide. Heatrex cannot be responsible for heater failures due to corrosion.

Table III

Legend	Sheath Material													Notes
	Max. Operating Temperature °F °C		Max. Watt Density W/In ² W/cm ²		Carbon Steel	Copper	INCONEL® 600	INCOLOY® 800	MONEL® 400	304 and 321 SS	316 SS	C276 Hastelloy®	Titanium	
A = Good to Excellent B = Fair to Good C = Depends on Conditions X = Not Suitable Blank = Data Not Available														
Heated Material	Corrosion Rating													
Acetic Acid (100%)	100 200	38 93	30-40 10-15	4.7-6.2 1.5-2.3	X	X	C	B	BC	BC	A	A	A	
Acetic Acid (50%)	100 200	38 93	50-65 20-25	7.8-10.1 3.1-3.9	X	X	X	B	B	C	A	BC	A	
Acetaldehyde	180	82	10	1.6		X	B		B	A	A	C	A	
Allyl Alcohol					B	A	A	A	A	A	A	B	B	2
Alcohol					B	A	A	A	A	B	A	B	A	2
Alcohol (Butyl)	110	43	5-7	0.8-1.1	BC	A	A	A	A	A	A	B	B	2
Alcohol (Ethyl)	100 150	38 66	5-7 3	0.8-1.1 0.5		A		A	A	B				
Alcohol (Methyl)	100 150	38 66	10-12 5	1.6-1.9 0.8		A		A	A	B				
Alkaline Cleaners			30-40	4.7-6.2						B				1
Alkaline Solutions	212	100	23	3.6	B									
Aluminum Acetate	120	49	10	1.6	X	B	B		B	AB	A	A	A	
Aluminum Chloride (Aqueous)					X	X	X	X	X	X	X	A	X	1
Aluminum Cleaners					C	X	A	A	A	A	A		B	1, 9
Aluminum Sulphate (Sat.)					X	X	X	BC	X	BC	BC	BC	A	1
Alum					X	X	BC	BC	X	X	BC	BC	A	1
Ammonia (Anhydrous)					A	X	A	C	A	B	A	A	A	
Ammonia (Sat. Liquid)	120	49	10-12	1.6-1.9	B					B	A		A	
Ammonia Chloride (50%)							A				A			
Ammonia (Gas)					C	X	B	C	X	A	A	A	A	
Ammonium Bifluoride					X	X	X	X	B	X	B	B	X	
Ammonium Chloride (50%)					X	X	A	C	A	C	C	A	A	
Ammonium Hydroxide (25%)					BC	X	A	A	X	A	A	B	A	
Ammonium Nitrate					A	X	X	BC	X	A	A		C	
Ammonium Persulphate					X	X	C	C	X	C	B			

Watt Density & Sheath Selection

Table III (continued)

Legend	Sheath Material													Notes
	Max. Operating Temperature °F °C		Max. Watt Density W/In ² W/cm ²		Carbon Steel	Copper	INCONEL® 600	INCOLOY® 800	MONEL® 400	304 and 321 SS	316 SS	C276 Hastelloy®	Titanium	
A = Good to Excellent B = Fair to Good C = Depends on Conditions X = Not Suitable Blank = Data Not Available														
Heated Material	Corrosion Rating													
Ammonium Sulphate (<40%)					X	X	B	A	B	C	B	B	A	
Amyl Alcohol			20	3.1	A	A	B	B	BC	B	B	B	A	2
Aniline (Commercial)	100 200 300	38 93 149	40-55 30-55 10-15	6.2-8.5 4.7-8.5 1.6-2.3		B		A		A				
Anodizing					X	X	X	X	X	X	X	A	X	
Arsenic Acid					X	C	X	B	X	B	B	C	X	
Asphalt (Tar)	200-500	93-260	5-9	0.8-1.4	A	X	A	A	X	A	B	B	A	2
Barium Hydroxide (Sat.)					B	X	B	B	C	B	B	B	AC	
Barium Sulphate			55	9	C	B	B	AC	B	B	B	B	A	
Beer			30-40	4.7-6.2	X	B	A	B	A	AC	A	A	B	
Benzene	100 150	38 66	20-25 10-15	3.1-3.9 1.6-2.3	A			A		A				
Black Liquor			15	2.3	X	X			BC	BC	BC	C		
Bleach 5.5% Cl, Clorox™			15-20	2.3-3.1	X					BC	BC	AC		
Boric Acid	250	121	40	6.2	X	C	C	A	BC	BC	BC	A	A	
Brass Cyanide										A				1
Bright Nickel			23	3.6									A	1, 5
Brine (Salt Water)			55	8.5	X	BC	AC	AC	B	C	B	A		10, 11
Bronze Plating					A					A				1
Cadmium Plating										A				
Calcium Chlorate	200	93	40	6.2	B	X	B	B	B	BC	BC	B	B	
Calcium Chloride (30% Solution)	100 190	38 88	20-25 5-8	3.1-3.9 0.8-1.2		B							A	
Calcium Chloride (Sat.)			23	3.6	B	B	B	B	B	BC	B	A	A	
Carbon Dioxide - Dry Gas			10-23	1.6-3.6	B	BC	A	A	A	A	A	A	AC	
Carbon Dioxide - Wet Gas			10-23	1.6-3.6	X	X	A	A	A	B	B	B	BC	2
Carbon Tetrachloride			23-26	3.6-4.0	C	AC	A	A	A	A	A	AC	A	1
Carbolic Acid (Phenol)					B	X	A	AC	AC	A	A	A	A	1
Castor Oil			23-26	3.6-4.0	A	AC	A	A	A	BC	B	A	A	1
Caustic Etch			15-26	2.3-4.0	A	C	A	A	A	A	A	BC	A	6
Caustic Soda	180	82	25-40	3.9-6.2				B						2
Chlorine Gas - Dry					C	C	B	A	AC	C	BC	B	X	
Chlorine Gas - Wet					X	X	X	X	C	X	X	BC	X	
Chloroacetic Acid					X	X	C	C	C	X	X	AC	A	

Watt Density & Sheath Selection

Table III (continued)

Legend	Sheath Material													Notes
	Max. Operating Temperature °F °C		Max. Watt Density W/In ² W/cm ²		Carbon Steel	Copper	INCONEL® 600	INCOLOY® 800	MONEL® 400	304 and 321 SS	316 SS	C276 Hastelloy®	Titanium	
Heated Material	Corrosion Rating													
Chloroform	100 140	38 60	10-15 5-8	1.6-2.3 0.8-1.2				A			A			
Chromic Acid (40%)	180	82	40	6.2	X	X	X	X	X	BC	B	B	A	
Citric Acid (Conc.)	180	82	23	3.6	X	X	B	AC	B	BC	A	A	A	1
Clear Chromate											A		A	1
Cod Liver Oil			23-26	3.6-4.0			A	A		A	A			1
Copper Bright										A				1
Copper Chloride					X	X	X	B	X	X	X	B	A	
Copper Cyanide						X	BC	B	X	B	B	A	AC	
Copper Fluoborate							B	B	B	B	B			
Copper Nitrate					X	X	X	BC	X	A	A	C	B	
Copper Pyrophosphate										A				1
Copper Strike					A					A				1
Copper Sulphate					X	X	BC	B	X	B	B	B	A	
Creosote			6-15	0.9-2.3	A	BC	B	B	B	B	B	B	A	2
Cresylic Acid (50%)					BC		C	C	X	B	A	B	B	2
Deoxidizer (3AL-13 Non-Chrome)										A	A			1
Detergents			40-50	6.2-7.8		A		B		A	B	AC	A	
Dichromic Seal					X					A	A			1
Diethylene Glycol					AC	B	B	B	B	A	A	B	A	1
Diphenyl C ₁₂ H ₁₀	600	316	10-15	1.6-2.3	A			A		A				
Dowtherm - A	100 200 300 400	38 93 149 204	55-60 40-50 20-35 3-5	8.5-9.3 6.2-7.8 3.1-5.4 0.5-0.8	A			A		A				
Dowtherm - G	675	357			A			A		A				
Dur-Nu™													A	1, 5
Electro Cleaner					A			A						1
Electroless Nickel													A	1
Electroless Tin (Alkaline)											A		A	1
Ethers, General					B	B	B	A	B	A	A	B	B	2
Ethyl Chloride					B	B	A	A	B	A	A	B	A	2
Ethylene Glycol (100% Solution)	200 300 390	93 149 199	30-40 20-30 5-10	4.7-6.2 3.1-4.7 0.8-1.6	A	B	B	A	B	B	A	A	A	

Watt Density & Sheath Selection

Table III (continued)

Legend	Sheath Material													Notes
	Max. Operating Temperature °F °C		Max. Watt Density W/In ² W/cm ²		Carbon Steel	Copper	INCONEL® 600	INCOLOY® 800	MONEL® 400	304 and 321 SS	316 SS	C276 Hastelloy®	Titanium	
A = Good to Excellent B = Fair to Good C = Depends on Conditions X = Not Suitable Blank = Data Not Available														
Heated Material	Corrosion Rating													
Fatty Acids			23-26	3.6-4.0	X	C	B	AC	B	BC	A	A	A	
Ferric Chloride					X	X	C	X	X	X	X	BC	A	
Ferric Nitrate (<50%)					X	X	X	BC	X	BC	B	BC	AC	
Ferric Sulphate					X	C	C	C	C	BC	AC	A	A	
Fluoboric Acid					AC	X			B	BC	AC	A	X	
Flourine Gas (Dry)					X	X	A	C	A	AC	A	BC	X	
Formaldehyde (<50%)					X	B	B	B	B	AC	AC	B	A	
Formic Acid (10-85%)					X	C	B	B	B	AC	B	A	C	
Freon (F-11, F-12, F-22)			3-9	0.5-1.4	C	B	A	A	A	A	A	B		
Fruit Juices (Pulp)			30-40	4.7-6.2	X		B	A	A	BC	B	A	A	
Fuel Oil 1&2 5&6 Bunker B&C	200 200 160	93 93 71	15-20 5-12 5-12	2.3-3.1 0.8-1.9 0.8-1.9	A B B	B A A	B A A	A B A	B A A	A A A	A A A	B A A	A	2, 3, 7
Fuel Oil (Acid)			6-10	0.9-1.6	X	X	C	C	C	C	B		A	2, 3, 7
Gasoline (Cracked)	200 300 400	93 149 204	35-45 15-25 3-6	5.4-7.0 2.3-3.9 0.5-1.0	B			A		A				2
Gasoline (Refined)	300	149	23	3.6	B	B	B	B	B	B	B	B		2, 5
Gasoline (Sour)			23	3.6	B	X	C	C	X	B	B	B		2, 3, 5
Glycerine (Glycerol)	300 500	149 260	15-20 3-5	2.3-3.1 0.5-0.8	B	A	A	A	A	A	A	A	A	
Grease (Liquid)			23	3.6	A									
Grease (Solid)			5	0.8	A									
Grey Nickel			23	3.6									A	1, 5
Hydrocarbons-Aliphatic			23-26	3.6-4.0	A	A	A	A	A	A	A	A		2
Hydrocarbons-Aromatic			23-26	3.6-4.0	A	A	A	A	A	A	A	A		2
Hydrochloric Acid (Dilute)			20-30	3.1-4.7	X	X	BC	BC	BC	X	X	AC	B	
Hydrochloric Acid (50%)			15-25	2.3-3.9	X	X	X	X	X	X	X	BC	X	
Hydrocyanic Acid (10%)					B	X	B	B	B	B	B			
Hydrofluoric Acid (Dilute)			23	3.6	X	X	BC	X	C	X	X	A	X	5
Hydrogen Peroxide (90%)			23-26	3.6-4.0	X	X	B	B	B	AC	AC	A	B	
Iridite™ - #4 - 75, #4 - 74, #14, #14 - 2, #14 - 9, #18 - P										A	A			1
Iridite™ - #1, #2, #3, #4-C, #4PC&S, #4P-4, #4-80, #4L-1, #4-2, #4-2A, #4-2P, #5P-1, #7, #7-P, #8, #8-P, #8-2, #12-P, #15, #17P, #18P					X	X	X	B	X	X	X	B	A	1

Watt Density & Sheath Selection

Table III (continued)

Legend	Sheath Material														
	Max. Operating Temperature °F °C		Max. Watt Density W/In ² W/cm ²		Carbon Steel	Copper	INCONEL® 600	INCOLOY® 800	MONEL® 400	304 and 321 SS	316 SS	C276 Hastelloy®	Titanium	Notes	
Heated Material	Corrosion Rating														
Iron Phosphate (Parkerizing™)												A	B	A	1
Isoprep™ Deoxidizer #187, #188												A			1
Isoprep™ Cleaner #186												A			1
Jetal™										A					1
Jet Fuel JP-4					B		A		B	BC	B	A	A		
Kerosene			23-26	3.6-4.0	B	BC	B	A	B	A	B	B			2
Lacquer Solvents			23-26	3.6-4.0	A	A	B	B	B	A	A		A		2
Lead Acetate					X	X	A	A	B	B	B	B	A		
Lead Acid Salts										B					1
Lime Saturated Water			23-40	3.6-6.2	B	B	B	B	B	B	A	A			
Linseed Oil	150	66	20	3.1	B	B	B	A	B	A	A				2
Lubricating Oil			23-26	3.6-4.0	A	A	A	A	B	B	B	B	A		7
Machine Oil			23-26	3.6-4.0	A		A	A	B	B	B	B	A		7
Magnesium Chloride					BC	B	A	B	B	C	B	A	A		
Magnesium Hydroxide					A	B	A	B	B	A	A	A	A		
Magnesium Nitrate					B	B	B	A	B	B	B	B	B		
Magnesium Sulfate					BC	BC	AC	B	A	B	B	B	B		
Mercuric Chloride					X	X	X	X	X	X	B	B	B		
Mercury			23-30	3.6-4.7	A	X	B	A	B	A	A	A	A		
Methanol (Methyl Alcohol)					B	B	A	A	A	B	B	A	A		2
Methyl Bromide					C	B	B	B	B	BC	A		A		
Methyl Chloride					X	B	B	C	B	AC	AC	B	A		
Methylene Chloride					BC	C	B	B	AC	B	B	A	A		
Milk			30-40	4.7-6.2	B	C	A	A	C	A	A	A			
Mineral Oil			23-26	3.6-4.0	B	B	A	AC	A	AC	B		A		
Molasses	100	38	4-5	0.6-0.8	A	A	A	A	A	A	A	A	A		
Naphtha					A	A	A	A	A	A	A		A		2
Nickel Acetate											A				1
Nickel Chloride			23	3.6	X	X	AC	B	B	BC	BC	A	A		1, 5
Nickel Plate-Bright			23	3.6	X		BC			C	C		B		1, 5
Nickel Plate-Dull			23	3.6	X		BC			C	C		B		1, 5
Nickel Plate - Watts Solution			23	3.6									A		1, 5
Nickel Sulphate					X	C	C	C	C	B	B				

Watt Density & Sheath Selection

Table III (continued)

Legend	Sheath Material													Notes	
	Max. Operating Temperature °F °C		Max. Watt Density W/In ² W/cm ²		Carbon Steel	Copper	INCONEL® 600	INCOLOY® 800	MONEL® 400	304 and 321 SS	316 SS	C276 Hastelloy®	Titanium		
A = Good to Excellent B = Fair to Good C = Depends on Conditions X = Not Suitable Blank = Data Not Available															
Heated Material	Corrosion Rating														
Nickel Copper Strike (Cyanide Free)											AC	AC			
Nitric Acid (20 - 30%)			15	2.3	X	X	BC	AC	X	AC	AC	AC	A		
Nitric & Hydrochloric Acid			15	2.3	X	X	C	X	X	BC	BC		X		
Nitric & 6% Phosphoric Acid			15	2.3								A			1
Nitric & Sodium Chromate												A			1
Nitric & Sulfuric Acid (50% - 50%)			15	2.3			X	X	X	AC	AC				
Nitrobenzene					B	BC	B	B	B	B	B	B	A		2
Oakites™ 20, 23, 24, 30, 51, 67, 90	210	99	30-40	4.7-6.2	A			A		A					1
Oil, SAE 10-20	250	121	15-20	2.3-3.1	A		A	A	B	A					
Oil, SAE 40-60	160	71	5-12	0.8-1.9	A		A	A	B	A					
Oleic Acid					BC	B	A	AC	BC	AC	AC	B	AC		
Olive Oil			23-26	3.6-4.0	B	B			B	B	B	AC	A		
Oxalic Acid (50%)					X	B	AC	AC	B	X	B	B	X		
Paint Stripper (High Alkaline)			30-40	4.7-6.2	A										1
Paint Stripper (Solvent)			23-26	3.6-4.0						A					1, 2
Paraffin	400	204	15-20	2.3-3.1	A	A	B	A	B	A	A	A			2, 7
Parkerizing™	SEE IRON PHOSPHATE														
Peanut Oil			23-26	3.6-4.0							B	A			
Perchloroethylene			23	3.6	A	B	A	A	A	AC	AC	B	A		
Petroleum Oils (Refined)			23-26	3.6-4.0	B	B			A	A	A				2, 3, 7
Petroleum Oils (Sour)			15-23	2.3-3.6	B	X			X	B	B				2, 3, 7
Phenol (Carbolic Acid)	SEE CARBOLIC ACID														
Phosphates (Generic)			23-40	3.6-6.2							BC	AC	B		1, 9
Phosphate Cleaners			23-40	3.6-6.2							BC	AC	B		1, 9
Phosphatizing			23	3.6								A			1, 5, 9
Phosphoric Acid (25% - 50%)			23	3.6	X	AC	BC	C	C	AC	BC		X		5, 9
Picric Acid					X	X	C	BC	X	BC	B	B			
Plating Solutions - Brass			23-35	3.6-5.4							B	AC	A		1
Plating Solutions - Cadmium			23-35	3.6-5.4							B	AC	A		1
Plating Solutions - Chrome (25%)			23-35	3.6-5.4	X	X	X	BC	X	BC	B	AC	X		1
Plating Solutions - Chrome (40%)			15-20	2.3-3.1	X	X	X	X	X	BC	B	AC	A		1
Plating Solutions - Cobalt			23-35	3.6-5.4							A				1

Watt Density & Sheath Selection

Table III (continued)

Legend	Sheath Material													
	Max. Operating Temperature °F °C		Max. Watt Density W/In ² W/cm ²		Carbon Steel	Copper	INCONEL® 600	INCOLOY® 800	MONEL® 400	304 and 321 SS	316 SS	C276 Hastelloy®	Titanium	Notes
Heated Material	Corrosion Rating													
Plating Solutions - Copper			23-35	3.6-5.4								AC	AC	1
Plating Solutions - Gold (Cyanide)			15-20	2.3-3.1						AC	AC	AC	AC	1
Plating Solutions - Gold (Acid)			15-20	2.3-3.1	A								A	1
Plating Solutions - Silver			23-35	3.6-5.4						AC	AC	AC	A	1
Plating Solutions - Tin			23-35	3.6-5.4							C	AC	X	1
Plating Solutions - Tin-Alkaline			15-20	2.3-3.1	A					A				1
Plating Solutions - Zinc			23-35	3.6-5.4								AC	A	1
Plating Solutions - Zinc Cyanide			15-20	2.3-3.1	A					A				1
Potassium Aluminum Sulphate					X	C				C	BC	BC	A	
Potassium Bichromate					C	C	B	B	B	B	B	B	AC	
Potassium Chloride (30%)					BC	X	AC	B	AC	AC	A	B	A	
Potassium Cyanide (30%)					BC	X	B	B	B	B	B	B	X	
Potassium Hydroxide (27%)					BC	C	B	B	B	BC	B	B	X	
Potassium Nitrate (80%)					B	BC	BC	B	B	B	B	B	A	
Potassium Sulphate (10%)					BC	BC	AC	BC	A	A	A	A	A	
Rochelle Salt - Cyanide					A					A				1
Santowax (C ₁₈ H ₃₄)	600	316	15-20	2.3-3.1	A			A		A				
Silicon Oils			23-26	3.6-4.0	B	AC				B	B			
Silver Bromide (10%)					X	X		AC	C	X	X	AC	A	
Silver Cyanide					C	X		AC	BC	AC	AC	AC	A	
Silver Lume										A				1
Silver Nitrate					X	X	BC	BC	X	B	AC	AC	AC	
Soap Solutions			55	8.5	BC	BC	AC	AC	BC	BC	BC	AC		3
Sodium Bichromate (Neutral)					B	C	B	B		B	B	B	C	
Sodium Bisulphate					C	X	BC	BC	BC	BC	BC	B	BC	
Sodium Bromide (10%)					C	C	B	B	B	C	BC	B	C	
Sodium Carbonate					C	BC	A	AC	A	BC	B	AC	A	
Sodium Chlorate					X	BC	A	AC	AC	BC	B	A	A	
Sodium Chloride (25% Solution)	100 150 200	38 66 93	55-75 50-55 25-30	8.5-11.6 7.8-8.5 3.9-4.7	C	B	AC	A	AC	C	C	B	A	11
Sodium Citrate					X	X	AC	AC	B	BC	B	BC	A	
Sodium Cyanide			30-40	4.7-6.2	X	X	BC	BC	X	AC	AC	BC	C	

Watt Density & Sheath Selection

Table III (continued)

Legend	Sheath Material												
A = Good to Excellent B = Fair to Good C = Depends on Conditions X = Not Suitable Blank = Data Not Available	Max. Operating Temperature °F °C	Max. Watt Density W/In ² W/cm ²	Carbon Steel	Copper	INCONEL® 600	INCOLOY® 800	MONEL® 400	304 and 321 SS	316 SS	C276 Hastelloy®	Titanium	Notes	
Heated Material	Corrosion Rating												
Sodium Dichromate (Hot Seal)				BC	X				BC	BC	AC	A	1
Sodium Hydroxide (50%)		15	2.3	C	X	AC	B	AC	AC	AC	AC	AC	6, 8
Sodium Hypochlorite (20%)		20	3.1	X	X	X	X	X	X	X	X	A	
Sodium Nitrate		23	3.6	B	C	A	A	BC	AC	AC	BC	AC	5
Sodium Peroxide (10%)				BC	X	BC	B	B	BC	B	B		
Sodium Phosphate (Neutral)				B	B	B	B	B	B	B	B	B	
Sodium Salicylate				B		B	B	B	B	B			
Sodium Silicate				B	X	B	AC	A	BC	B	B	A	4
Sodium Sulfate				B	BC	B	AC	BC	AC	A	B	C	
Sodium Sulfide (<50%)				X	X	B	AC	B	BC	BC	B	C	
Sodium Stannate				C		B	B	B	B	B			
Sodium Thiosulfate (Hypo)				X	X	B	B	BC	B	B	BC	AC	
Steam (Medium Pressure)		10-15	1.6-3.1	C	BC	A	A	AC	BC	BC	B		
Stearic Acid				C	BC	B	AC	C	BC	A	A	A	
Sugar Solution		10-23	1.5-3.6	A	A	A	A	A	A	A	A	A	7
Sulfamate Nickel												A	1
Sulfamic Acid				X	C				BC			AC	
Sulfur				X	X	A	A	BC	A	A	A	A	
Sulfur Chloride (Dry)				X	X	B	AC	X	BC	BC	B		
Sulfur Dioxide (Dry)		15-23	2.3-3.6	AC	BC	B	AC	B	B	B	B	A	
Sulfur Dioxide (Wet)		10-20	1.5-3.1	X	X	X	BC	X	X	B	AC	A	
Sulfuric Acid (10 - 50%)		15	2.3	X	X	X	BC	X	X	X	AC	X	
Sulfuric Acid (98%)		15	2.3	X	X	X	BC	X	X	BC	AC	X	
Sulfurous Acid				X	X	BC	A	X	X	BC	B	A	
Tannic Acid				X	C	B	B	B	B	B	B	AC	
Therminol™ 44 (Max. Bulk Temp. 425°F)	425	218	25-30	3.9-4.7	A		A		A				
Therminol™ 55 (Max. Bulk Temp. 575°F)	575	302	25-30	3.9-4.7	A		A		A				
Therminol™ 60 (Max. Bulk Temp. 600°F)	600	316	25-30	3.9-4.7	A		A		A				
Therminol™ 66 (Max. Bulk Temp. 650°F)	100	38	25-30	3.9-4.7	A		A		A				
	300	149	25-30	3.9-4.7									
	500	260	25-30	3.9-4.7									
	600	316	20-25	3.1-3.9									
650	343	10-15	1.6-2.3										

Watt Density & Sheath Selection

Table III (continued)

Legend	Sheath Material												Notes		
	Max. Operating Temperature °F °C		Max. Watt Density W/in ² W/cm ²		Carbon Steel	Copper	INCONEL® 600	INCOLOY® 800	MONEL® 400	304 and 321 SS	316 SS	C276 Hastelloy®		Titanium	
A = Good to Excellent B = Fair to Good C = Depends on Conditions X = Not Suitable Blank = Data Not Available															
Heated Material	Corrosion Rating														
Therminol™ 88 (Max. Bulk Temp. 600°F) (Liquid only at 293°F)			30-40	4.7-6.2	A			A		A					
Therminol™ FR-1 (Chlorinated Biphenyl)	100	38	20-25	3.1-3.9											
	200	93	20-25	3.1-3.9											
	300	149	20-25	3.1-3.9	A			A		A					
	400	204	10-15	1.6-2.3											
	500	260	3-5	0.5-0.8											
Tin (Molten)			20	3.1		X	X		X	X	X				4
Trichloroethane					A	A	A	A	A	A	A	A	A		
Trichloroethylene	70		20-25												
	100		15-20		BC	A	AC	A	A	A	B	A	A		
	180		3-7												
Triethylene Glycol			23	3.6	A	A	A	A	A	A	A				
Trisodium Phosphate					BC	BC			BC	AC	AC	AC			
Turco™ 4181 (Alkaline Cleaner)											A				1
Turco™ 4008 (Descaler)											A				1, 5
Turco™ 4338 (Oxidizer)											A				1, 7
Turco™ Ultrasonic Solution											A				1
Turpentine	68	20	30-40	4.7-6.2				A			A				
Udylite™ #66			23	3.6									A		1, 5
Vegetable Oil	100	38	30-35	4.7-5.4											
	300	149	15-20	2.3-3.1											
	400	204	5-10	0.8-1.6	B			A		B	A				
	550	288	2	0.3											
Water, Deionized	100	38	75	11.6	X	B	A	A	C	A	A	B			10
	212	100	50-75	7.8-11.6											
Water, Demineralized	100	38	75	11.6	X	X	A	A	C	A	A	B			10
	212	100	50-75	7.8-11.6											
Water, Pure (Distilled)	100	38	75	11.6	X	X	A	A	A	A	A	A			10
	212	100	50-75	7.8-11.6											
Water, Process	100	38	75	11.6	X	B	A	A	B	BC	BC	B	A		10, 11
	212	100	50-75	7.8-11.6											
Water, Potable	100	38	75	11.6	X	B	A	A	B	BC	BC	B	A		10, 11
	212	100	50-75	7.8-11.6											
Water, Salt Brine			55	8.5	X	BC	AC	AC	B	C	B	A			10, 11
Water, Sea	100	38	75	11.6	X	BC	BC	AC	A	C	BC	AC	A		10, 11
	212	100	50-75	7.8-11.6											
Whiskey			55	8.5	X	BC	B		A	A	A	AC			2
Wines			55	8.5	X	BC			B	A	A	A			
Yellow Dichromate											A				1

Watt Density & Sheath Selection

Table III (continued)

Legend	Sheath Material												
	Max. Operating Temperature °F °C	Max. Watt Density W/in ² W/cm ²	Carbon Steel	Copper	INCONEL® 600	INCOLOY® 800	MONEL® 400	304 and 321 SS	316 SS	C276 Hastelloy®	Titanium	Notes	
A = Good to Excellent B = Fair to Good C = Depends on Conditions X = Not Suitable Blank = Data Not Available													
Heated Material	Corrosion Rating												
Zinc Chloride				X	X	B	BC	BC	X	B	B	B	
Zinc Phosphate		23	3.6							A			1, 5
Zincate™				A					A				1

Notes:

- 1 - This solution contains an unknown mixture of various chemical compounds whose proportions could change without our knowledge. Consult the chemical supplier to confirm the suitability or for alternate sheath materials.
- 2 - Caution - Flammable material, maintain complete immersion.
- 3 - Exact chemical composition can vary widely. Consult the chemical supplier to confirm suitability.
- 4 - Direct immersion heaters are not normally suitable. Consider using a clamp-on heater on the outside of a pot.
- 5 - Element watt density should not exceed 23 w/in².
- 6 - For concentrations greater than 15% the element watt density should not exceed 15 w/in².
- 7 - Concentration vary widely, consult the supplier to confirm suitability.
- 8 - Remove crusts at the liquid level.
- 9 - Clean frequently.
- 10 - Passivate stainless steel for the maximum effectiveness.
- 11 - Stainless steel materials may be subject to chloride or stress corrosion cracking in this application.

Watt Density & Sheath Selection

Heating Metals – Table IV gives recommended watt densities and sheath selection for elements that are clamped or inserted. Allowable watt densities will vary with such factors as element fit in a machined opening and metal thickness.

This information should be used only as a guide. Heatrex cannot be responsible for heater failures due to corrosion or excessive temperatures in the application.

Table IV

Application	Maximum Metal Temperature °F	Recommended Watt Density W/Sq. In.	Recommended Sheath Material
Clamped to Flat Metal Surface	200	20	Steel
	200	30	304 SS
	400	20	304 SS
Inserted into Machined Grooves or Holes	200	25	Steel
	200	35	304 SS
	400	25	304 SS
	600	20	304 SS
	600	25	Incoloy
	800	15	Incoloy

Terminals, Insulators & Seals

Except as noted, various terminations, insulators and seals can be combined as required to fit the application.

Table V

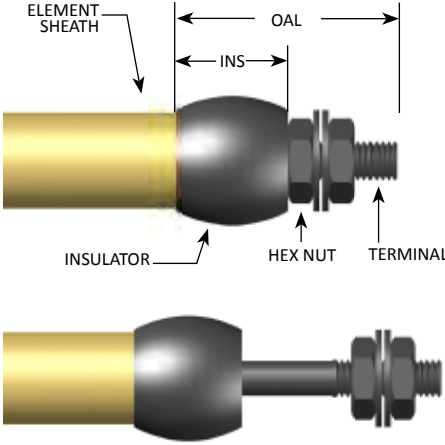
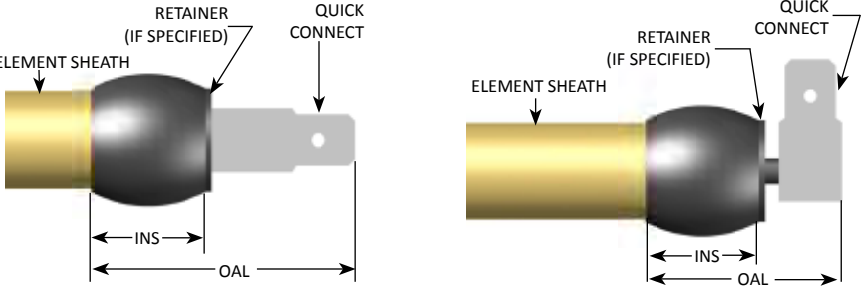
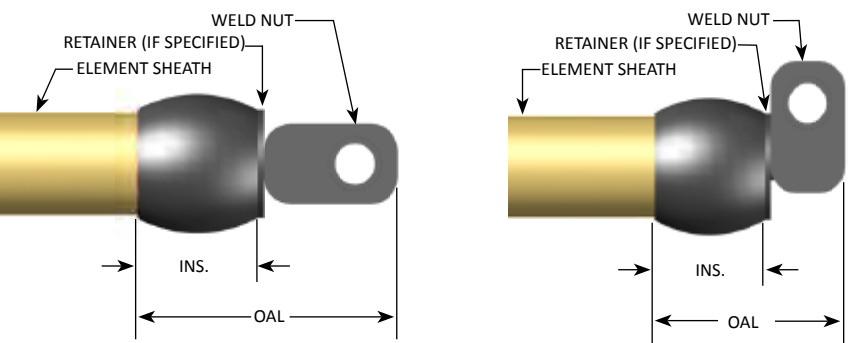
<p>Terminal #1:</p> <p>Threaded Terminal (standard)</p> <p>Description: Stainless steel stud with threaded length</p> <p>Optional: Insulators available in silicone rubber (std) or optional mica or ceramic where available</p> <p>Use: For lead attachment in the field. 600V rating</p>	 <table border="1" data-bbox="1117 470 1531 695"> <thead> <tr> <th>Thread Sizes*</th> <th>OAL Standard</th> <th>INS Standard (Insulator Dim)</th> </tr> </thead> <tbody> <tr> <td>6-32</td> <td rowspan="4">1"</td> <td rowspan="4">0.50"</td> </tr> <tr> <td>8-32</td> </tr> <tr> <td>10-32</td> </tr> <tr> <td>1/4-20</td> </tr> </tbody> </table> <p>* 6-32 thread is standard for .250 and .260 Element Diameters, 10-32 thread is standard for all other Diameters. Other thread size, INS and OAL lengths available upon request.</p>	Thread Sizes*	OAL Standard	INS Standard (Insulator Dim)	6-32	1"	0.50"	8-32	10-32	1/4-20			
Thread Sizes*	OAL Standard	INS Standard (Insulator Dim)											
6-32	1"	0.50"											
8-32													
10-32													
1/4-20													
<p>Terminal #2:</p> <p>Quick Connect Terminal</p> <p>Description: Standard 1/4" plated steel quick connect configuration</p> <p>Optional: Insulators available in silicone rubber (std) or optional mica or ceramic where available</p> <p>Use: For connection to matching female terminal on field finished lead. 30 amp max, see table for voltage rating</p>	 <table border="1" data-bbox="740 1230 1531 1360"> <thead> <tr> <th>Voltage Range</th> <th>OAL Standard (Straight terminal)</th> <th>OAL Standard (90 Deg terminal)</th> <th>INS Standard (Insulator Dim)</th> </tr> </thead> <tbody> <tr> <td>0-250V</td> <td>0.75"</td> <td>0.813"</td> <td>0.25</td> </tr> <tr> <td>251-600V</td> <td>1"</td> <td>1.063"</td> <td>0.5</td> </tr> </tbody> </table>	Voltage Range	OAL Standard (Straight terminal)	OAL Standard (90 Deg terminal)	INS Standard (Insulator Dim)	0-250V	0.75"	0.813"	0.25	251-600V	1"	1.063"	0.5
Voltage Range	OAL Standard (Straight terminal)	OAL Standard (90 Deg terminal)	INS Standard (Insulator Dim)										
0-250V	0.75"	0.813"	0.25										
251-600V	1"	1.063"	0.5										
<p>Terminal #3:</p> <p>Weld Nut</p> <p>Description: Tab with internal thread is welded to terminal pin and furnished with terminal screw</p> <p>Use: Where it is more convenient to use this terminal orientation.</p>	 <table border="1" data-bbox="691 1770 1479 1917"> <thead> <tr> <th>Voltage Range</th> <th>OAL Standard (Straight terminal)</th> <th>OAL Standard (90 Deg terminal)</th> <th>INS Standard (Insulator Dim)</th> </tr> </thead> <tbody> <tr> <td>0-250V</td> <td>0.813"</td> <td>0.563"</td> <td>0.25</td> </tr> <tr> <td>251-600V</td> <td>1.063"</td> <td>0.813"</td> <td>0.5</td> </tr> </tbody> </table>	Voltage Range	OAL Standard (Straight terminal)	OAL Standard (90 Deg terminal)	INS Standard (Insulator Dim)	0-250V	0.813"	0.563"	0.25	251-600V	1.063"	0.813"	0.5
Voltage Range	OAL Standard (Straight terminal)	OAL Standard (90 Deg terminal)	INS Standard (Insulator Dim)										
0-250V	0.813"	0.563"	0.25										
251-600V	1.063"	0.813"	0.5										

Terminals, Insulators & Seals

Table V (continued)

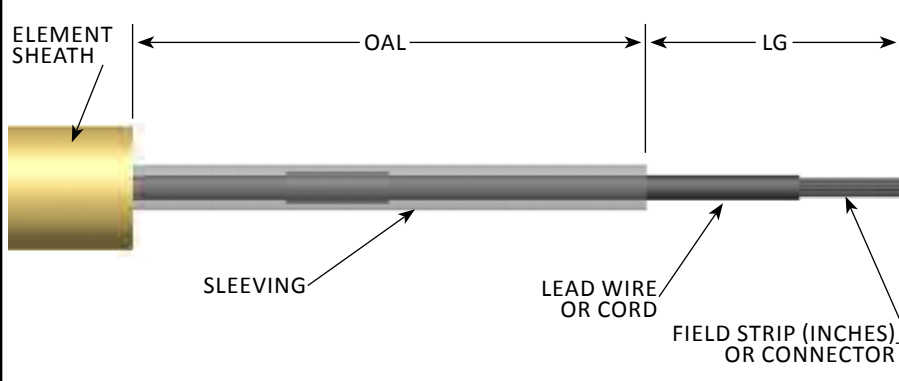
<p>Terminal #4:</p> <p>Neoprene Insulated Leads</p> <p>Description: Standard Bare Copper or Tin Plated Copper Conductors insulated with Neoprene. 90°C Neoprene insulation with thickness of 5/64" or 1/16".</p> <p>Use: Used primarily for internal wiring or wiring of defrost and refrigeration applications up to 600V. See Neoprene and Epoxy filled Terminal #5 for applications that require protection for wet (immersed) refrigeration type applications. <i>Neoprene exhibits supreme abrasion, cut-through oil, and solvent resistance. Neoprene is also known for its long service life and wide ranges of temperature and usability. It is remarkably flame retardant and self-extinguishing. (Military products often incorporate Neoprene.)</i></p>	<p>PVC Insulated Leads</p> <p>Description: Standard Bare Copper or Tin Plated Copper Conductors insulated with PVC. 105°C PVC insulation with thickness of 1/32".</p> <p>Use: Used primarily for internal wiring of appliances up to 600V or with thickness of 1/16" for internal wiring of refrigeration equipment. See Valox Terminal #5 for applications that require protection for moist refrigeration type applications. <i>PVC is relatively inexpensive, with the potential to be used in diverse applications. It is flame, moisture, and abrasion resistant. It also holds up against gasoline, ozone, acids, and solvents. PVC should not be used when flexibility and an extended flex life are required at low temperatures.</i></p>	<p>Silicone Insulated Leads with Glass Braid (SRG)</p> <p>Description: Stranded Tin Plated Copper Conductors insulated with Silicone Rubber and Glass Braid. 200°C Silicone Rubber insulation with thickness of 1/32".</p> <p>Use: Used primarily for internal wiring of appliances up to 600V. SRG is the standard supplied insulation material, with the exception of defrost and refrigeration applications.</p>									
 <p>The diagram illustrates a lead wire assembly. On the left is a yellow cylindrical 'ELEMENT SHEATH'. To its right is a grey 'SLEEVE'. Further right is a thin 'LEAD WIRE OR CORD'. The 'FIELD STRIP (INCHES) OR CONNECTOR' is the section where the sleeve and lead wire meet. Dimension lines indicate 'OAL' (Overall Assembly Length) from the start of the sleeve to the end of the field strip, and 'LG' (Lead Wire Length) from the start of the lead wire to the end of the field strip.</p> <table border="1" data-bbox="162 1617 779 1869"> <thead> <tr> <th>Standard Supplied Wire Gauge</th> <th>Limit Amps</th> </tr> </thead> <tbody> <tr> <td>18</td> <td>10</td> </tr> <tr> <td>16</td> <td>15</td> </tr> <tr> <td>14</td> <td>20</td> </tr> <tr> <td>12</td> <td>30</td> </tr> </tbody> </table>	Standard Supplied Wire Gauge	Limit Amps	18	10	16	15	14	20	12	30	<p>Type TGGT Leads</p> <p>Description: Stranded Nickel-Clad Copper Conductors insulated with PTFE tapes and Glass Braid. 250°C PTFE tapes with thickness of 1/64" covered by wrapped fiberglass yarns and a treated glass braid jacket.</p> <p>Use: Used where the leadwire is exposed to high temperatures such as in industrial processing up to 600V.</p>
Standard Supplied Wire Gauge	Limit Amps										
18	10										
16	15										
14	20										
12	30										
<p>Mica Insulated Leads with Glass Braid (MGT)</p> <p>Description: Stranded Nickel-Clad Copper Conductors insulated with Mica Glass Tapes and Glass Braid. 450°C Glass reinforced Mica tapes with thickness of 1/32" and a treated glass braid jacket.</p> <p>Use: Used where the leadwire is exposed to extremely high temperatures up to 600V.</p>											

Terminals, Insulators & Seals

Table V (continued)

Terminal #5:

Defrost Terminal

Description:
Neoprene or Valox, Injection Molded overmold terminal

OR

Epoxy Filled Metal Cup Terminal

Description:
Epoxy resin fills a metallic adapter enclosing the connection between lead wire and element cold pin.

Use:
Primarily defrost applications and others where water may drop on the terminal end. UL Recognized under File SA3254.

Type	Material	Type	Element Sizes	OD	OAL	Location	Description
Overmold QC	Neoprene	One-Pass	0.250 - 0.315	0.4375	1.0625	Moist	T Series
Epoxy Cup SM	Epoxy/Metal	One-Pass	0.315	0.5625	1.25	Wet	Blank Series
Epoxy Cup LG	Epoxy/Metal	One-Pass	0.475	0.5625	1.75	Wet	Blank Series
Overmold	Neoprene	One-Pass	0.250 - 0.375	0.4375	1.75	Wet	W Series
Overmold	Neoprene	One-Pass	0.430 - 0.490	0.75	1.75	Wet	W Series*
Overmold	Valox	One-Pass	0.250 - 0.315	0.4375	1.75	Moist	J39 Series
Overmold	Valox	One-Pass	0.375 - 0.430	0.5625	1.75	Moist	J39 Series
Overmold	Valox	One-Pass	0.475	0.75	1.5	—	—*
Epoxy Cup LG	Epoxy/Metal	Two-Pass	0.475	0.5625	1.75	—	—*
Overmold	Neoprene	Two-Pass	0.430 - 0.490	0.75	1.5	Moist	X Series

* May be recognized under E78533

Grounding Strap (Optional)

Description:
To ground long straight single-pass finned tubular elements, eliminating arcing due to secondary currents.

Use:
Recommended for straight single-pass finned tubular elements over on expansion end. Verify adequate expansion clearances.

Terminals, Insulators & Seals

Table V (continued)

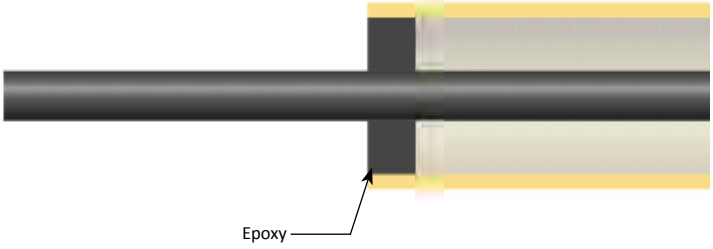
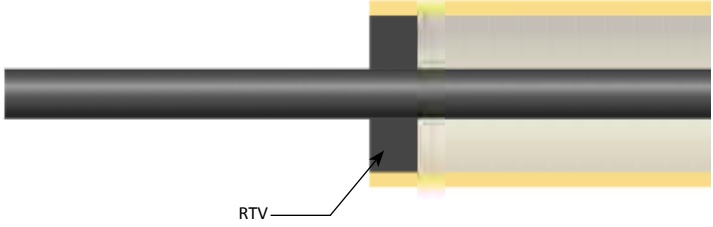
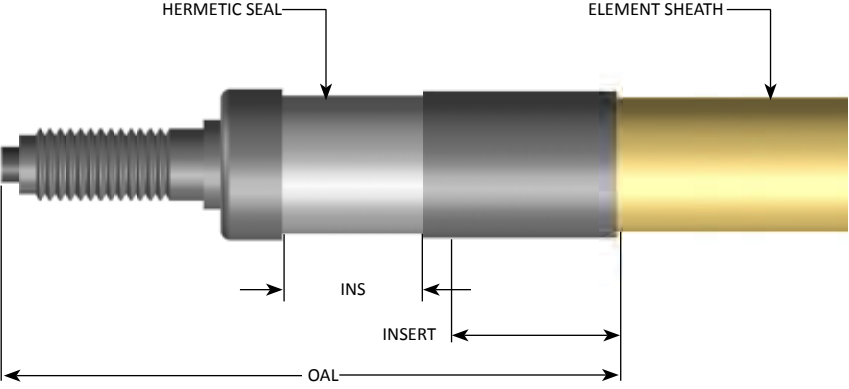
<p>End Seal #1:</p> <p>Epoxy Barrier</p> <p>Description: Epoxy resin fills a 1/4" cavity above the magnesium oxide insulation, to form a barrier against moisture.</p> <p>Use: For applications where low to moderate humidity may be present in the terminal area. For use at 266°F maximum for 0.315 element and above. 194°F maximum for 0.260 elements and below.</p>	 <p style="text-align: center;">Epoxy</p>									
<p>End Seal #2:</p> <p>RTV Barrier</p> <p>Description: RTV sealant forms a barrier against moisture.</p> <p>Use: For high temperature applications where temperatures may range up to 392°F or 428°F.</p>	 <p style="text-align: center;">RTV</p>									
<p>End Seal #3:</p> <p>Hermetic Seal</p> <p>Description: Ceramic to metal hermetic seal is soldered to the element sheath and cold pin.</p> <p>Use: Absolute moisture seal up to 1000°F.</p> <p>Element Sheath: Available in element diameters .430 and .475, consult factory for other availability.</p>	 <table border="1" data-bbox="737 1654 1382 1829"> <thead> <tr> <th>Element Sheath Diameter</th> <th>INS Standard (Integral Ceramic Insulator Dim)</th> <th>OAL Standard</th> </tr> </thead> <tbody> <tr> <td>0.430</td> <td>0.5</td> <td>2.125"</td> </tr> <tr> <td>0.475</td> <td>0.5</td> <td>2.125"</td> </tr> </tbody> </table> <p style="text-align: center;">Alternate element sheath diameters available upon request.</p>	Element Sheath Diameter	INS Standard (Integral Ceramic Insulator Dim)	OAL Standard	0.430	0.5	2.125"	0.475	0.5	2.125"
Element Sheath Diameter	INS Standard (Integral Ceramic Insulator Dim)	OAL Standard								
0.430	0.5	2.125"								
0.475	0.5	2.125"								

Terminals, Insulators & Seals

Table V (continued)

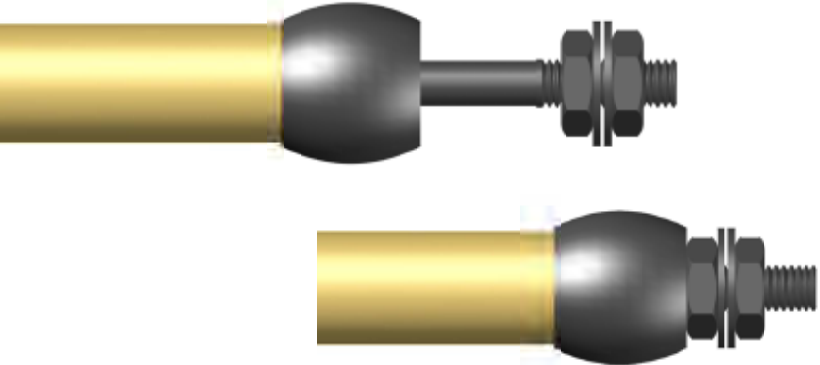
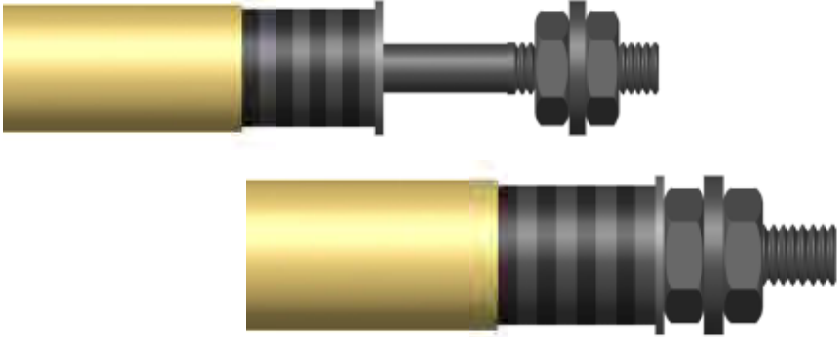
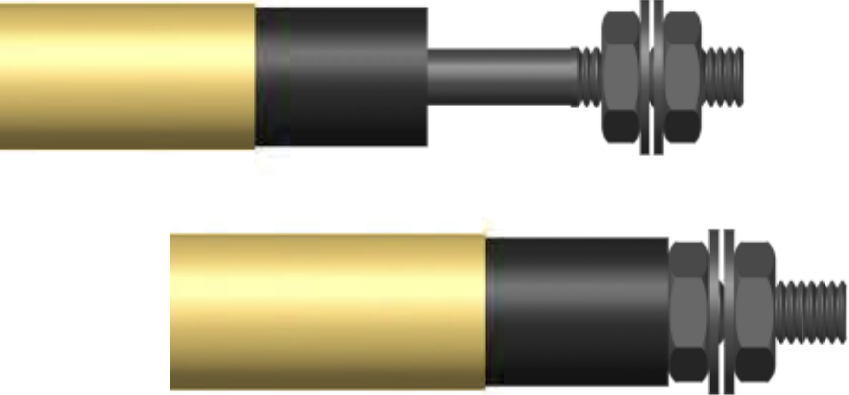
<p>Insulator #1:</p> <p>Silicone Rubber (standard)</p> <p>Description: General applications where terminal temperatures do not exceed 400°F. 1/4" thick insulation furnished up to 250V; 1/2" thick up to 600V. (Standard insulator unless otherwise specified)</p>	
<p>Insulator #2:</p> <p>Mica</p> <p>Description: Applications where terminal temperatures do not exceed 900°F. 1/4" thick insulation furnished up to 250V; 1/2" thick up to 600V.</p>	
<p>Insulator #3:</p> <p>Ceramic</p> <p>Description: Applications where terminal temperatures do not exceed 1400°F. 1/4" thick insulation furnished up to 250V; 1/2" thick up to 600V.</p>	

Bending

Standard single-pass tubular elements may be bent in an infinite variety of configurations. Utilizing the most up-to-date computer numerical control (CNC) bending equipment and techniques, Heatrex is able to produce an element to fit virtually any application.

Certain bends are normally repressed on unfinned elements to recompact the magnesium oxide insulation, eliminating hairline cracks that may develop during bending. As described in the following table.

Element Diameter	Normally Repress if C-C less than
0.200	1
0.250/0.260	1.375
0.315	1.5625
0.375	1.75
0.430	1.875
0.475/0.490	2
0.625	2.5

The Figures 5 through 39 on the following pages show some of the configurations frequently specified. For configurations not shown, submit a drawing or sketch of your requirements. Any of these are available either finned or unfinned.

Table VI

Element Diameter	Sheath Materials	Minimum Bend Radius for 180° Bends	Minimum Bend Radius for 90° Bends
0.200	Incoloy 840	0.225	0.1625
0.250	304 SST	0.25	0.1875
	321 SST	0.25	
	Incoloy 840	0.25	
	Incoloy 800	0.3125	
	Monel	0.25	
	CUPLDSTL	0.25	
	Copper	0.25	
0.260	304 SST	0.255	0.1925
	321 SST	0.255	
	Incoloy 840	0.255	
	Incoloy 800	0.3175	
	Monel	0.255	
	CUPLDSTL	0.255	
0.315	304 SST	0.4075	0.2825
	316 SST	0.37125	
	321 SST	0.37125	
	Incoloy 840	0.37125	
	Incoloy 800	0.4075	
	Monel	0.4075	
	CUPLDSTL	0.4075	
	Steel	0.4075	
Copper	0.4075		
0.375	304 SST	0.37125	0.3125
	321 SST	0.37125	
	Incoloy 840	0.4375	
	Incoloy 800	0.4375	

Element Diameter	Sheath Materials	Minimum Bend Radius for 180° Bends	Minimum Bend Radius for 90° Bends
0.430	304 SST	0.37125	0.37125
	316 SST	0.37125	
	321 SST	0.37125	
	Incoloy 840	0.5	
	Incoloy 800	0.5	
	Monel	0.5	
	Inconel 600	0.59	
	CUPLDSTL	0.4375	
	Steel	0.4375	
	Copper	0.4375	
	0.475	304 SST	
316 SST		0.5	
321 SST		0.5	
Incoloy 840		0.5	
Incoloy 800		0.5	
Monel		0.5	
Inconel 600		0.7375	
Steel		0.5	
Copper		0.5	
0.490	304 SST	0.5	0.40125
	316 SST	0.5	
	321 SST	0.5	
	Incoloy 840	0.5	
	Incoloy 800	0.5	
	Monel	0.62	
	Inconel 600	0.745	
Steel	0.62		
0.625	321 SST	0.8125	0.5625
	Incoloy 840	0.8125	
	Inconel 600	0.9375	

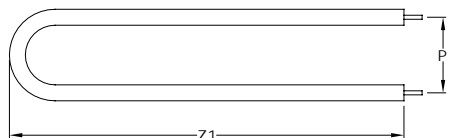

FIGURE 5

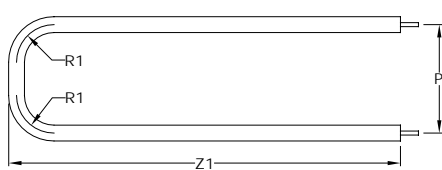

FIGURE 6

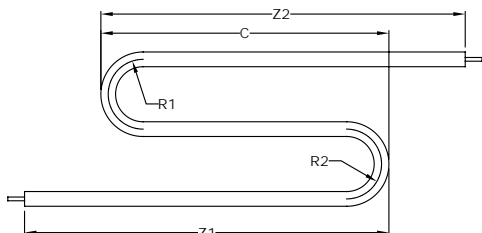

FIGURE 8

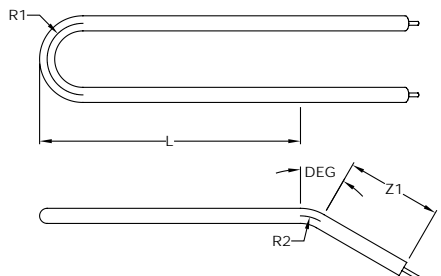

FIGURE 9

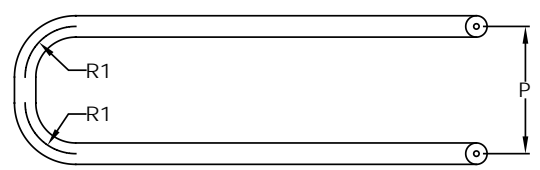

FIGURE 10



FIGURE 11

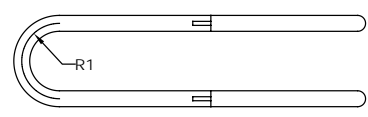

FIGURE 12

Bending

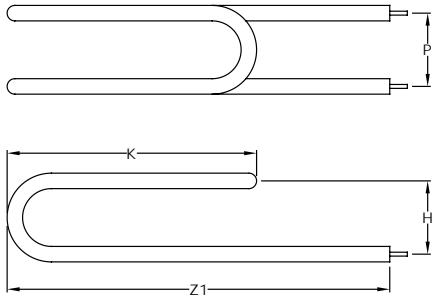

FIGURE 13

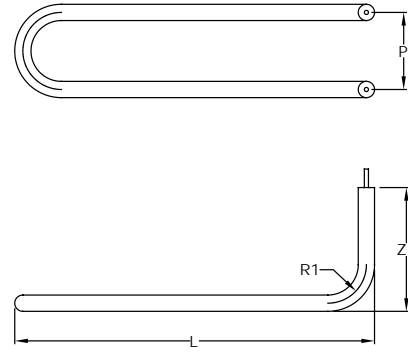

FIGURE 16

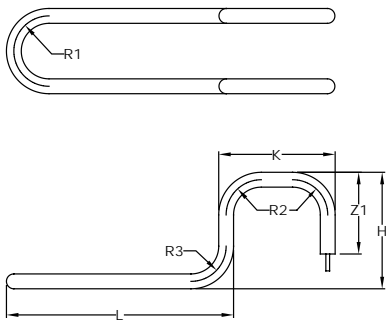

FIGURE 14

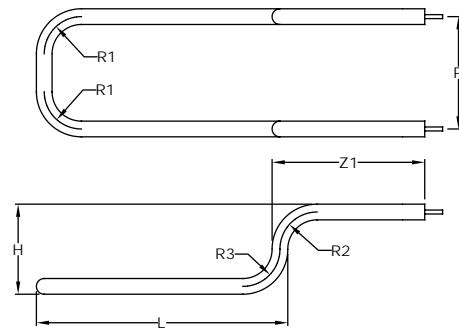

FIGURE 17

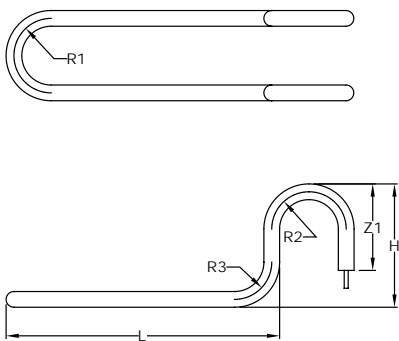

FIGURE 15

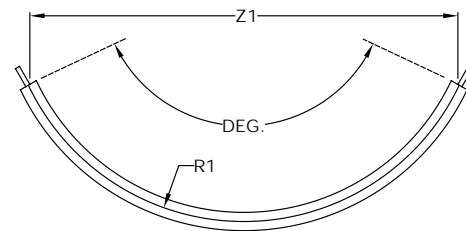

FIGURE 18

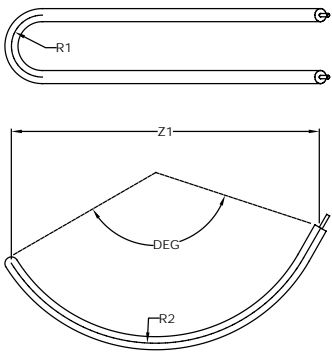

FIGURE 19

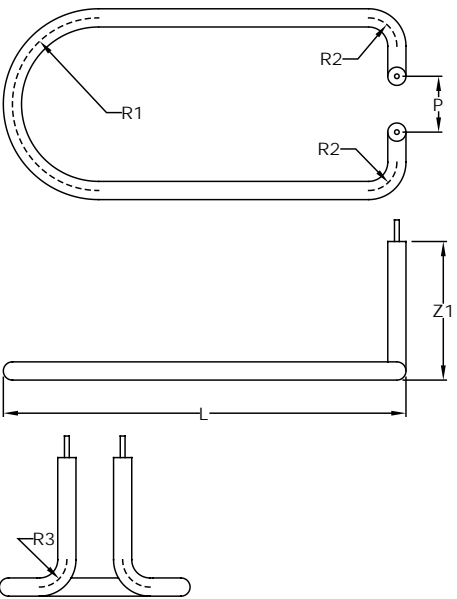

FIGURE 20

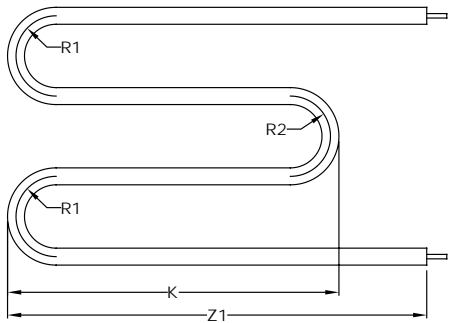

FIGURE 21

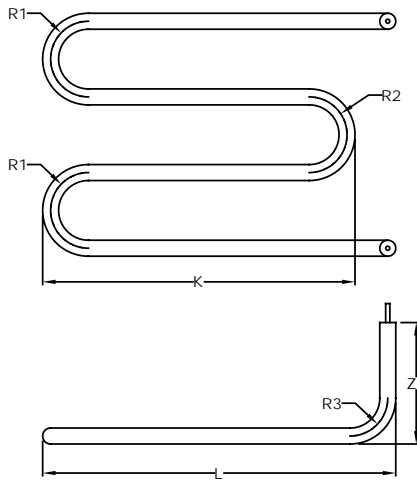

FIGURE 22

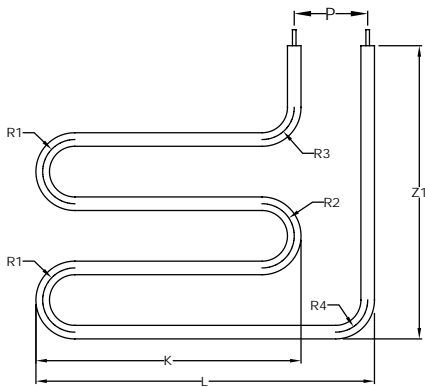

FIGURE 23

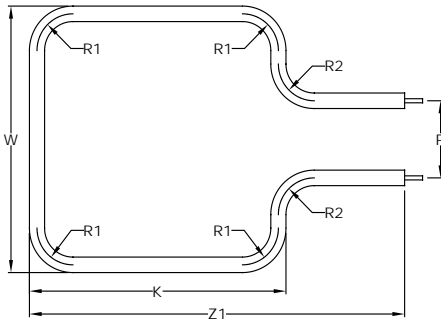

FIGURE 24

Bending

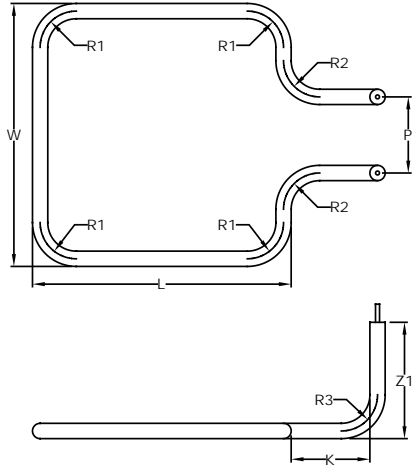

FIGURE 25

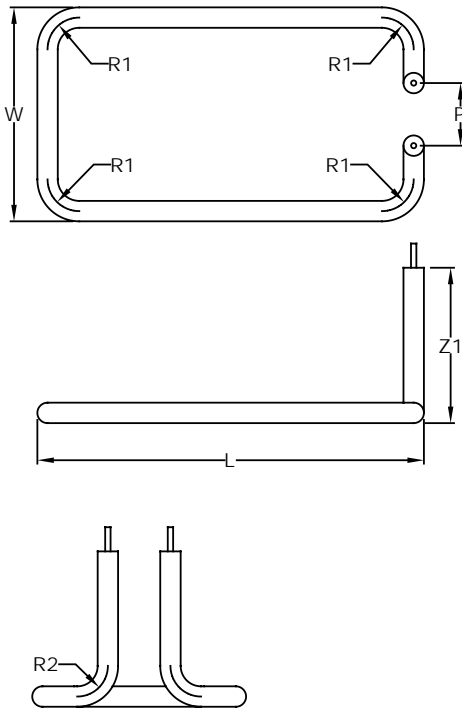

FIGURE 26

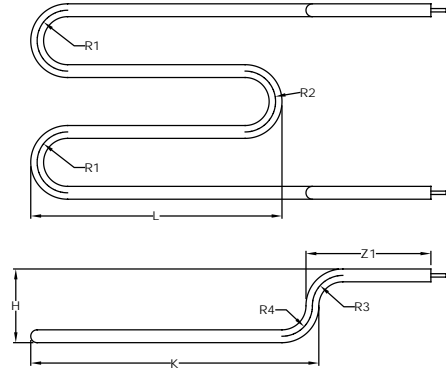

FIGURE 27

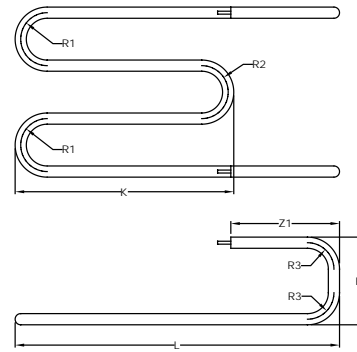

FIGURE 28

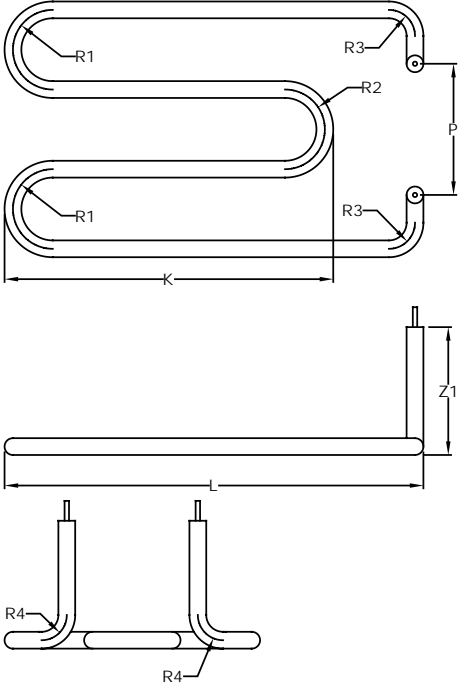

FIGURE 29

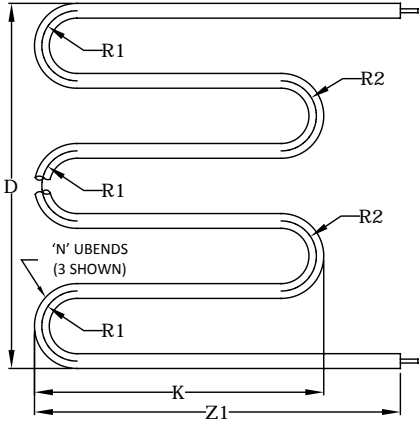

FIGURE 30

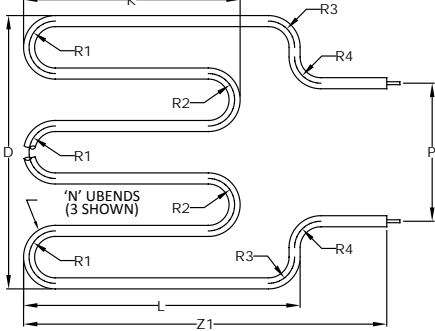

FIGURE 31

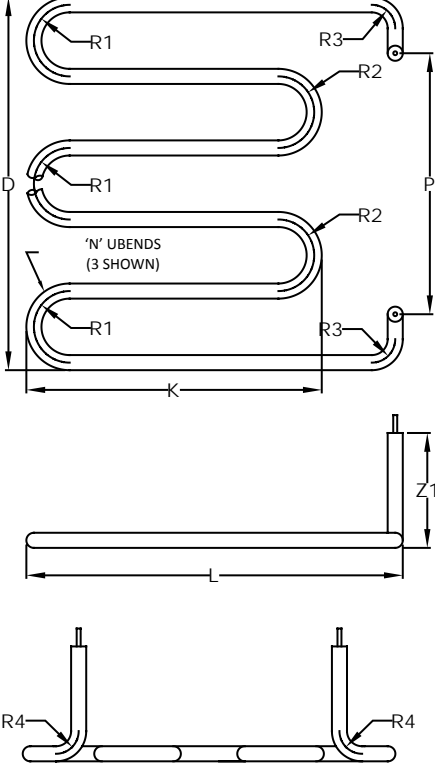

FIGURE 32

Bending

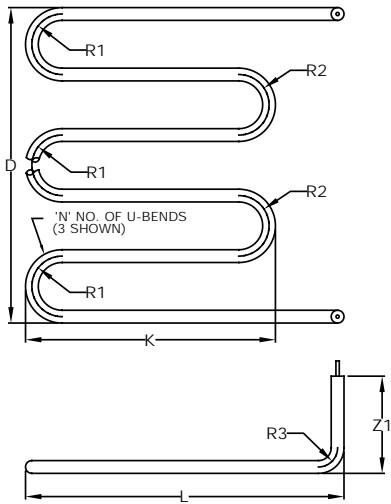

FIGURE 33

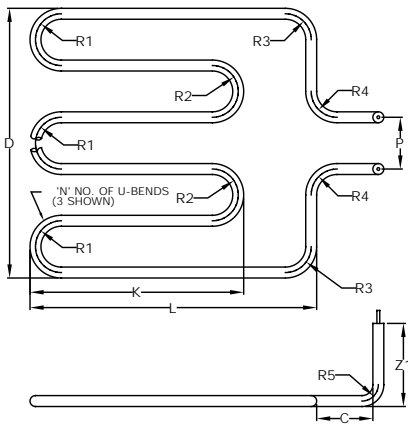

FIGURE 34

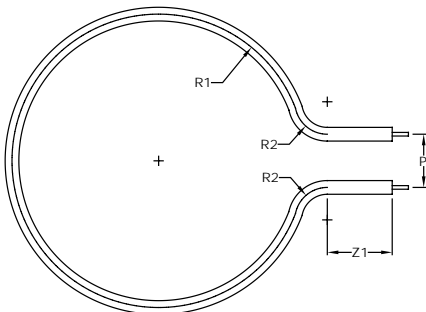

FIGURE 35

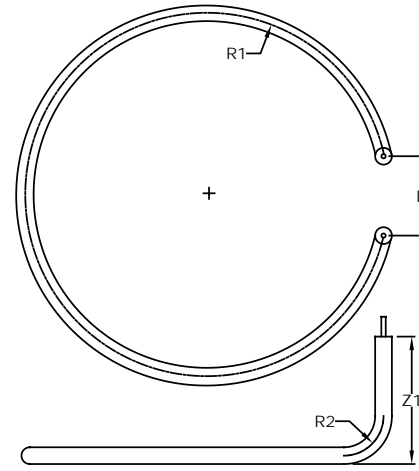

FIGURE 36

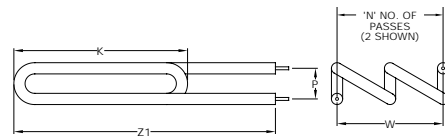

FIGURE 37

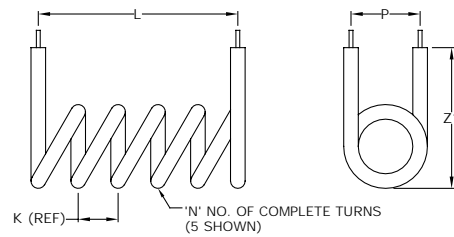

FIGURE 38

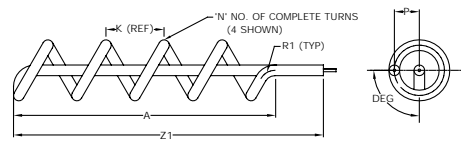

FIGURE 39

Mounting Accessories

Two types are available: Threaded Fittings and Mounting Plates.

Threaded Fittings

Threaded fittings are furnished with nuts and optional fiber gaskets, washers and lockwashers. Fittings are silver soldered, welded or mechanically pressed (staked) to the sheath. Welding requires sheath and fitting material compatibility. Standard elements may be provided with two fittings, one for each terminal end. Two-pass elements may be provided with only one fitting.

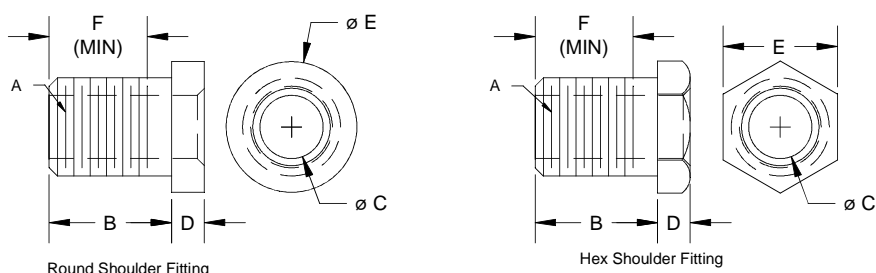

Dimensional details shown in Table VII

Table VII

C Element Diameter	Fitting Part No.	Shoulder Type	Material	A Thread Size	B Length	D Shoulder Thk	E Head Size	F Min. Thrd. Length
0.250/0.260	60000425	Hex	SST	7/16-20UNF	0.56	0.13	0.63	0.425+
0.250/0.260	60000428	Hex	BRS	1/2-20UNF	0.50	0.13	0.75	0.43
0.250/0.260	86-2-C-3	Round	BRS	1/2-20UNF	0.63	0.13	0.75	0.55
0.260	86-3-C-74	Hex	BRS	1/2-20UNF	0.69	0.19	0.75	0.61
0.315	60000326	Hex	SST	7/16-20UNF	0.56	0.13	0.63	0.425+
0.315	1007121	Round	BRS	7/16-28UNEF	0.56	0.31	0.75	0.51
0.315	86-22-C-1	Hex	BRS	1/2-20UNF	0.50	0.19	0.75	0.43
0.315	86-22-ZC-2*	Hex	BRS	1/2-20UNF	0.50	0.19	0.75	0.43
0.315	86-3-UZ-1	Hex	303 SST	1/2-20UNF	0.63	0.13	0.75	0.488+
0.315	60000431	Round	SST	1/2-20UNF	0.81	0.13	0.75	0.675+
0.315	1007139	Round	BRS	1/2-20UNF	0.88	0.31	0.75	0.80
0.315	86-37-C-1	Hex	BRS	1/2-20UNF	1.00	0.25	0.75	0.93
0.315	1007219	Round	BRS	9/16-18UNF	0.50	0.13	1.00	0.42
0.315	1007142	Round	BRS	5/8-18UNF	0.50	0.31	1.00	0.42
0.315	86-62-C-1	Hex	BRS	5/8-18UNF	0.75	0.19	0.88	0.67
0.315	60000384	Hex	SST	5/8-18UNF	0.81	0.13	0.88	0.73
0.375	60000324	Hex	BRS	1/2-20UNF	0.56	0.13	0.75	0.49
0.375	60000198	Hex	303 SST	9/16-18UNF	0.69	0.13	0.75	0.542+
0.375	86-3-UZ-81	Hex	303 SST	9/16-18UNF	1.00	0.13	0.88	0.854+
0.430	86-47-C-1	Round	BRS	9/16-18UNF	1.00	0.25	0.75	0.92
0.430	86-36-C-2	Hex	BRS	5/8-18UNF	0.50	0.19	0.88	0.42
0.430	60000320	Hex	SST	5/8-18UNF	0.63	0.13	0.88	0.48
0.430	86-36-C-1	Hex	BRS	5/8-18UNF	0.75	0.19	0.88	0.67
0.430	60000396	Hex	SST	5/8-18UNF	1.00	0.13	0.88	0.854+
0.430	86-3-C-7	Hex	BRS	5/8-18UNF	1.06	0.19	0.88	0.98
0.430	60000352	Hex	BRS	3/4-16UNF	0.81	0.19	1.00	0.72
0.430	60000337	Hex	SST	3/4-16UNF	1.06	0.19	1.00	0.97
0.475	1007127	Round	BRS	5/8-18UNF	0.56	0.31	1.00	0.48

* Tin plated brass

Mounting Accessories

Table VII (continued)

C Element Diameter	Fitting Part No.	Shoulder Type	Material	A Thread Size	B Length	D Shoulder Thk	E Head Size	F Min. Thrd. Length
0.475	1006846***	Round	STEEL	5/8-18UNF	0.56	0.13	1.00	0.417+
0.475	1007118	Round	BRS	5/8-18UNF	0.81	0.31	1.00	0.73
0.475	1007276	Round	SST	5/8-24UNEF	0.75	0.13	1.00	0.625+
0.475	1007279	Hex	SST	3/4-16UNF	0.38	0.19	1.00	0.28
0.475	1000058**	Hex	STEEL	3/4-16UNF	0.50	0.13	0.88	0.41
0.475	1007225	Hex	BRS	3/4-16UNF	0.88	0.25	1.00	0.78
0.475	1007228	Hex	SST	3/4-16UNF	0.88	0.25	0.88	0.78
0.475	1007273	Hex	SST	3/4-16UNF	1.06	0.19	1.00	0.97
0.490	60000389	Hex	BRS	5/8-18UNF	0.50	0.13	0.88	0.42
0.490	60000138	Hex	SST	5/8-18UNF	0.88	0.19	0.88	0.729+
0.490	60000317	Hex	SST	3/4-16UNF	0.56	0.13	1.00	0.47
0.490	60000070	Hex	SST	3/4-16UNF	1.06	0.19	1.00	0.97
0.625	60000410	Hex	STEEL	7/8-14UNF	1.00	0.13	1.13	0.83+
0.625	60000373	Hex	SST	7/8-14UNF	1.13	0.13	1.13	0.955+
0.625	60000008	Hex	SST	7/8-14UNF	1.38	0.13	1.13	1.205+
0.625	60000375	Round	STEEL	7/8-14UNF	1.88	0.13	1.25	1.705+

+ Fitting has a 1/16" weld projection not included in the "F" dimension shown. Consult factory for details.

** This fitting is copper plated steel, normally furnished on finned tubular elements with palnut type locknuts standard. Gaskets are not furnished unless specified.

*** Nickel plated steel

Other fittings available, contact factory.

Mounting Plates

Mounting plates provide a simple, convenient means of holding elements in place in an airstream and other applications where the element is not immersed in a liquid. Stainless steel plates are mechanically pressed (staked) or tack welded to sheathed elements.

The mounting plates shown to the right are standard configurations for .475" diameter elements. Consult factory for other diameters and configurations.

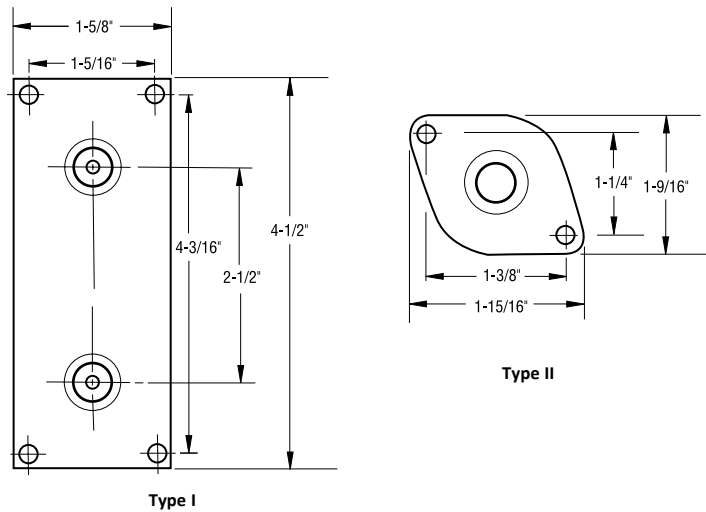

Table VIII

Heating Element Configuration	Mounting Plate	
	Type	Material
2-1/2" C-C U-Bent	I	Stainless
Straight or Two-Pass	II	Stainless

Limited Warranty

Heatrex products are warranted against defects in workmanship, material, design, labeling and packaging. No other warranty, expressed or implied, written or oral, applies. No person other than an officer or the general manager of Heatrex is authorized to give any other warranty or assume any liability.

Warranty Period: This warranty is effective for eighteen months from the date of shipment of the product from Heatrex's factory, or for twelve months from the date the product is first placed in service, whichever period lapses first.

Conditions of Warranty: Heatrex products must be installed, operated and maintained in accordance with Heatrex's instructions. Heatrex is not liable for damage or unsatisfactory performance of the product resulting from accident, negligence, alteration, unauthorized repair, improper application or installation of the product, improper specifications or corrosion. HEATREX IS NOT LIABLE FOR ANY INCIDENTAL OR CONSEQUENTIAL DAMAGES. Claims against carriers for damage in transit must be filed by the purchaser with the carrier.

Remedy: Contact the Heatrex sales department at 814-724-1800 for a Return Material Authorization Number (RMA#) and return instructions.

If after receipt of the product and the claim, Heatrex finds to its reasonable satisfaction that the product is defective in workmanship, material, design, labeling or packaging, the product will be repaired or replaced or the purchase price refunded at Heatrex's option. There will be no charge to the purchaser for parts or labor. Removal and reinstallation of the product, and shipment of the product to Heatrex for repair or inspection shall be at the purchaser's risk and expense.

THE REPAIR, REPLACEMENT OR REFUND PROVIDED FOR IN THIS LIMITED WARRANTY IS THE EXCLUSIVE REMEDY OF THE PURCHASER. THIS WARRANTY IS EXPRESSLY IN LIEU OF ANY OTHER WARRANTIES, EXPRESSED OR IMPLIED, INCLUDING ANY WARRANTY OF MERCHANTABILITY OR FITNESS FOR A PARTICULAR PURPOSE. THERE ARE NO WARRANTIES WHICH EXTEND BEYOND THE TERMS OF THIS LIMITED WARRANTY.



231 Chestnut Street, Suite #410
Meadville, PA 16335

814-724-4800
Fax: 814-333-6580
www.heatrex.com