

# Custom Explosion-proof Duct Heaters

## Construction

Heaters are generally constructed per 220 Series (see page 57), except that element terminals as well as control components are built into a single cast aluminum explosion-proof enclosure.

**Frame** – Sized to fit the duct. Standard flanged design recommended to support heater weight. Slip-in also available, if necessary, to match other equipment. Galvanized steel standard; stainless steel optional.

**Control Enclosure** – NEMA 7, 9 cast aluminum box with hinged cover houses controls and element terminals. Weatherproof construction optional.

**Heating Elements** – Heavy wall, large diameter stainless steel finned tubular elements, individually removable for servicing.

**SCR Temperature Control** – SCR's with zero-cross firing provide precise proportional control. SCR's also minimize element operating temperatures for extra safety. Optional on/off single or multi-stage control also available.

**Overtemperature Protection** – Thermocouple controllers measure element sheath temperature.

- Automatic reset control resets when temperature drops to a safe level.
- Manual reset control, with external button, provides back-up protection.

**Fuses** – Individual circuit fusing for heaters drawing over 48 amps to meet NEC requirements.

**Airflow Interlock** – Fan relay prevents heater operation, unless fan is energized. Optional built-in or remote explosion-proof airflow switch can be provided.

**Magnetic Contactors** – Furnished as required for temperature and safety controls.

**Control Transformer** – Furnished as standard with fusing as required.

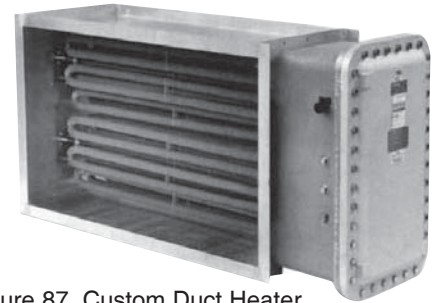

Figure 87. Custom Duct Heater

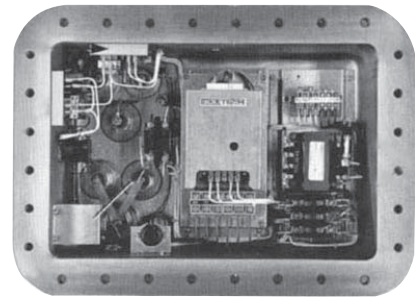

Figure 88. Control Enclosure

Class I, Division 1 and 2  
Groups C and D

Class II, Divisions 1 and 2  
Groups E, F, and G

Although built to hazardous safety standards,  
these heaters are not FM or CSA Approved.



# Custom Explosion-proof Duct Heaters

## How to Order

1. **Construction Type** – Standard flanged or optional slip-in. See Figures 89 and 90.
2. **Electrical Ratings** – Line voltage, KW, Phase and Control Voltage.
3. **Inside Duct Dimensions** – Width and Height.
4. **Temperature Control** – Staged or SCR Control. If staged, specify number of stages (one through ten). If SCR control, specify input signal.
5. **Airflow Direction** –
  - Horizontal (Right or Left).
  - Vertical (Up or Down).
6. **Airflow Volume** – Minimum flow in SCFM (Standard Cubic Feet per Minute) over the heater.
7. **Maximum Inlet Air Temperature** – Maximum of 80°F (27°C). If inlet air will be higher, consult factory.
8. **Classification of Hazardous Area** – Class, Group, Ignition Temperature and NEC I.D. Code No.
9. **Options** – Select from 220 Series Custom Option codes in **Table XXI** on page 52.

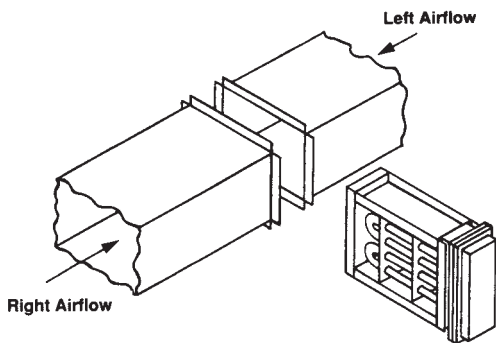

Figure 89. Standard Flanged Heater Installation

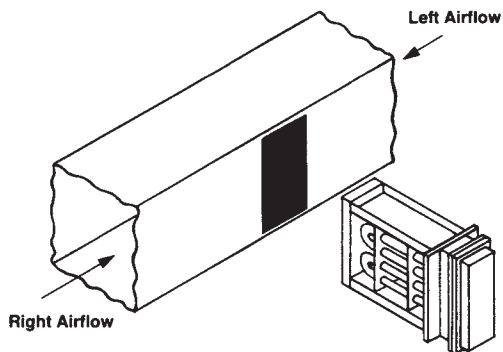

Figure 90. Optional Slip-in Heater Installation

## Sample Specification

A sample specification can be prepared by using the following information. A circle has been supplied so that you may darken those sections which you require. Material which is part of the standard Custom Explosion-proof Duct Heater specification has already been darkened.

- 1. Electric explosion-proof duct heaters shall be HEATREX custom explosion-proof, the KW rating, voltage, phase, duct size, construction type and airflow direction specified in the schedule. They shall be approved for:
  - Class I, Divisions 1 and 2, Groups C and D, and NEC Ignition Temperature I.D. Code Number \_\_\_\_\_ (please specify).
  - Class II, Divisions 1 and 2, Groups E, F, and G, and NEC Ignition Temperature I.D. Code Number \_\_\_\_\_ (please specify).
- 2. Duct heaters shall have automatic and manual reset thermal cutouts for redundant overtemperature protection, fan relay for airflow interlock, de-energizing controlling and backup magnetic contactors, 120 volt control circuit transformer, terminal blocks for field wiring and supplementary fusing for heaters over 48 amps. Controls shall be housed in a NEMA 7, 9 cast aluminum enclosure.
- 3. Duct heaters shall consist of industrial grade HEATREX stainless steel finned tubular electric heating elements mounted in a heavy-gauge galvanized steel frame.
- 4. Duct heaters shall be furnished with the control option indicated below (select one):
  - Single stage on/off control with field installed thermostat.
  - Multi-stage control with built-in step controller and field installed thermostat.
  - Solid-state control with built-in zero-cross switching SCR and field installed thermostat.
- 5. The following options are to be included:
  - Built-on disconnect switch.
  - Supplementary fusing for heaters drawing less than 48 amps.
  - Warning pilot light to indicate overtemperature or no airflow.
  - "Heater On" pilot light to indicate power to the heater.
  - Disconnecting magnetic contactors.
  - Built-on airflow switch in place of the fan relay.
  - 24 volt transformer in place of 120 volt transformer.
  - NEMA 4, 7, 9 gasketed box for wet locations.